

THEMATIC GUIDANCE CONFLICT PREVENTION

March 2026

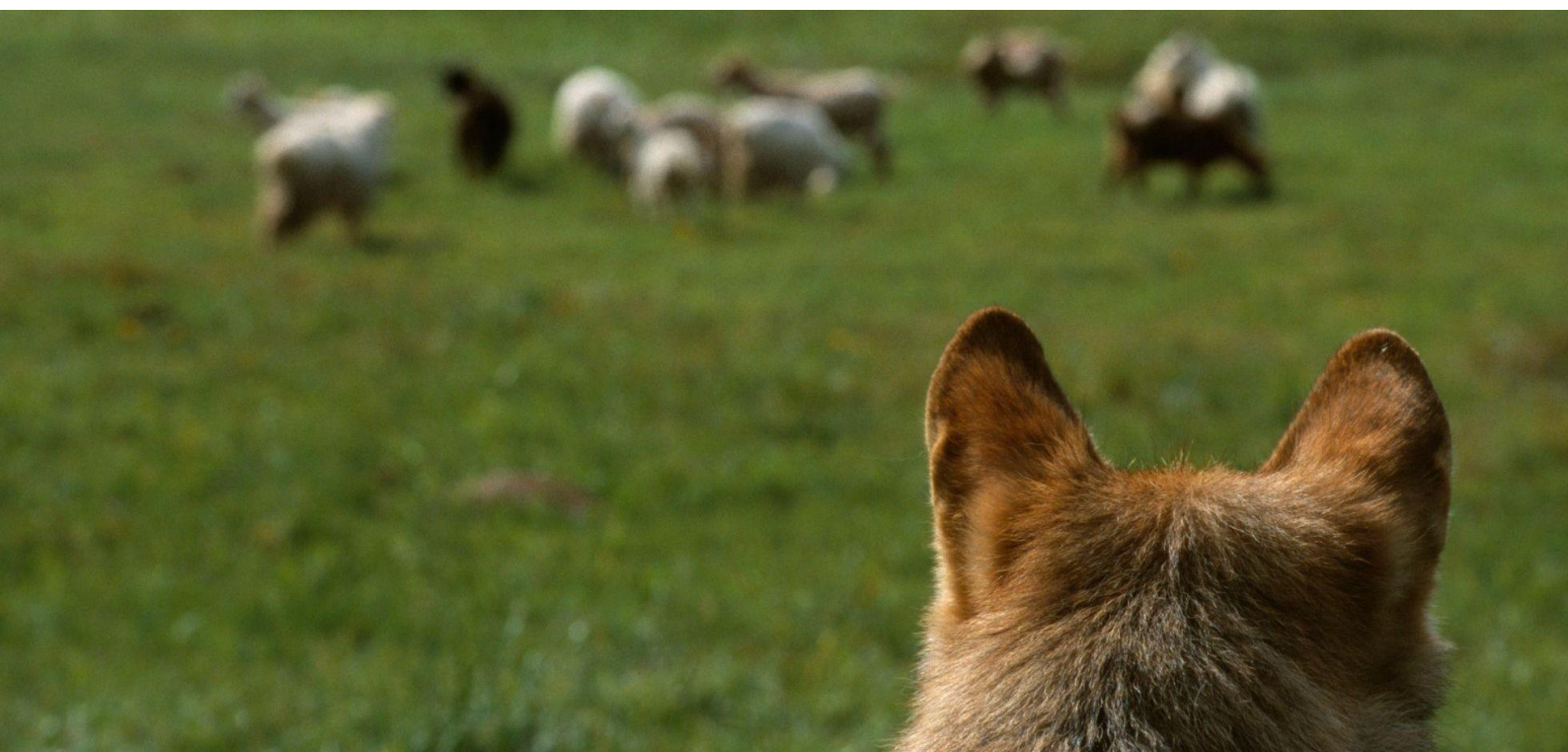

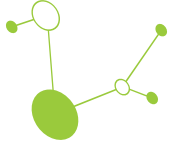

THEMATIC GUIDANCE CONFLICT PREVENTION

Authors: Sütő D.¹, Zwijacz-Kozica T.², Kubala J.³, Rzepkowski R.⁴, Mot R.⁵, Mirzoev D.⁶, Tám B.⁷, Oražem M. V.⁸, Berce T.⁸, Cherepanyn R.^{9,10}, Svitálek J.¹¹, Kissová L.¹¹, Duľa M.¹¹

1. WWF Hungary, Hungary
2. Tatra National Park, Poland
3. Technical university in Zvolen, Slovakia
4. WWF Poland, Poland
5. Zarand Association, Romania
6. Ministry of the Environment of the Czech Republic, Czechia
7. WWF Slovakia, Slovakia
8. Slovenia Forest Service, Slovenia
9. WWF Ukraine, Ukraine
10. Vasyl Stefanyk Carpathian National University, Ukraine
11. Mendel University in Brno, Czechia

Suggested citation: Sütő et al. 2026. – THEMATIC GUIDANCE CONFLICT PREVENTION - LECA – Supporting the coexistence and conservation of Carpathian Large Carnivores. Brno, March 2026, p. 39.

Cover photo: © Staffan Widstrand /WWF

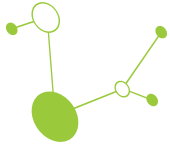

Content

1. Executive Summary	3
2. Introduction	4
3. Selected best practices from Carpathian cross-border pilot and reference areas in thematic pillar “Conflict prevention”	5
A. Identification of human-provided/anthropogenic attractants and hot-spot analyses	5
Livestock depredation	5
Human-bear conflicts	6
B. Removal of human-provided/anthropogenic attractants and application of prevention measures	7
Protection of livestock, including beehives	7
Practices against human-bear conflicts near humans	10
C. Establishment and using of funding and compensation schemes	12
D. Establishment and operation of local/regional/cross-border stakeholder platforms	14
Setting up the platforms: The bottom-up foundation	15
Operationalising platforms: From dialogue to action	15
E. Raising awareness and active involvement of stakeholders to prevent conflicts	15
4. Case studies from LECA Cross-border and Reference Areas	19
Case study 1: Identification of livestock depredation hotspots in the Beskydy-Kysuce pilot area	19
Case study 2: Identification of attractants related to human-bear conflicts in the Tatra pilot area near Zakopane	22
Case study 3: Implementation of preventive measures to protect livestock in the Slovak Karst & North Hungarian Mts. & Beskydy-Kysuce pilot areas	24
Case Study 4: Strengthening preventive measures and community engagement in the Bieszczady region	26
Case study 5: Best-practice example: Financial support mechanisms for livestock breeders in the Czech Republic	28
Case Study 6: Cooperation between practice and education in Slovenia	31
Case study 7: Romania’s first “Bear-Smart” community - integrated conflict mitigation approach in the Băile Tuşnad reference area	31
5. Lessons learned: Risks and recommendations	34
Summary of key potential risks and recommendations for their mitigation	35
6. References	37

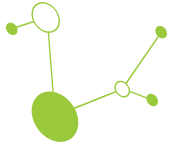

1. Executive Summary

The recovery and expansion of large carnivore populations across Europe, including the Carpathians, mark a major conservation success but have also increased conflicts with humans in shared landscapes. Addressing these conflicts is essential for both carnivore conservation and sustainable rural livelihoods. This Thematic Guidance on Conflict Prevention, developed under the LECA project, provides **concise, policy-oriented, and evidence-based guidance** to support human–carnivore coexistence and the implementation of the Carpathian Convention through **tested and transferable solutions**. It adopts a **holistic, prevention-focused approach**, promoting the integrated use of **technical measures, financial instruments, participatory governance, and stakeholder engagement** to address ecological, economic, and social drivers of conflict while reducing risks and improving societal acceptance.

Core Elements of the Guidance

The framework is structured around five mutually reinforcing pillars:

- **Conflict identification:** mapping livestock depredation and human–bear hotspots using monitoring and spatial analyses;
- **Preventive measures:** applying effective tools such as electric fencing, livestock-guarding dogs, and removal of food attractants (especially improved waste management);
- **Economic instruments:** combining compensation schemes with funding for preventive measures;
- **Participatory governance:** establishing multi-stakeholder platforms to support dialogue and coordinated action;
- **Awareness and social engagement:** strengthening knowledge, communication, and stakeholder involvement to address both ecological and social dimensions of conflict.

These elements are supported by **case studies from across the Carpathians**, demonstrating their practical effectiveness, and by a synthesis of lessons learned on risks and enabling conditions for success.

Key Policy Recommendations

Based on our findings to ensure effective and sustainable conflict prevention, decision-makers should prioritise:

- **Prevention-first policies** by systematically investing in proven preventive measures and define minimum technical standards.
- **Integrated financial frameworks** by linking compensation to prevention and implement both simultaneously ensuring predictable, long-term funding covering both investments and operational costs;
- **Strong participatory governance** by establishing bottom-up multi-stakeholder platforms to ensure legitimacy and trust;
- **Improved monitoring and data systems** by standardising data collection and use monitoring results to guide adaptive management;
- **Awareness and capacity building** by providing continuous information, training, and education on coexistence practices;
- **Policy stability and resilience** by embedding key measures in legislation and maintain long-term institutional cooperation.

Key Message

Sustainable coexistence with large carnivores is achievable, but requires **integrated, adaptive, and participatory approaches tailored to local contexts**. This guidance offers a **practical policy toolkit** to support effective, long-term conflict prevention across the Carpathian region.

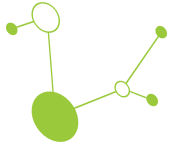

2. Introduction

Following severe historic persecution, large carnivores disappeared from many parts of Europe and their population reached the lowest levels by the mid twentieth century. Since then, many populations have shown a steady recovery across the continent. Although large carnivores persisted continuously in the core areas of the Carpathian region, countries such as Czechia and Hungary have witnessed their permanent return only in recent decades, while in other countries their populations also increased (Bernardi et al., 2025; Chapron et al., 2014). However, the recovery of these species does not come without an impact on human activities and vice versa. Given the absence of large areas of wilderness in Europe (Venter et al., 2016), large carnivores have almost entirely re-established their populations in highly human modified landscapes (Bautista et al., 2019; Bernardi et al., 2025; Boitani et al., 2022; Chapron et al., 2014) causing conflicts that may jeopardise the conservation outcomes if not adequately managed (Linnell, 2013). These processes can seriously impact population sizes and, in some cases, diminish the prospects for long term population viability. Therefore, providing effective and sustainable conflict prevention methods in the Carpathians is a top priority for both conservation and management.

In line with the strategic objective #3 of the Carpathian Action Plan – Improve coexistence of humans with large carnivores – this thematic guidance focuses on strengthening co-existence in the Carpathian region with a holistic approach including ecological, economical and social aspects, and providing practical solutions grounded in local realities focusing especially on human-wolf and human-bear conflicts.

This document was prepared within the framework of the LECA (Supporting the coexistence and conservation of Carpathian Large Carnivores – CE0100170) Interreg Central Europe project. The project aims to establish structured cross-border cooperation in large carnivore monitoring and conservation across pilot areas in the Czech Republic, Hungary, Poland, Ukraine and Slovakia, with reference areas in Slovenia and Romania. The present guidance forms part of a series of thematic documents designed to provide validated solutions and scalable strategies applicable at national, transnational, and Carpathian levels.

The document is structured as a comprehensive thematic guidance on conflict prevention and coexistence between humans and large carnivores in the Carpathian region. Outlining the increasing challenges linked to human–carnivore coexistence with the historical recovery of large carnivore populations in Europe, and the related objectives of the LECA project within the framework of the Carpathian Action Plan. The core chapters present selected best practices and validated approaches from Carpathian pilot and reference areas focusing on conflict prevention. These sections address the identification of conflict hotspots and anthropogenic attractants, livestock protection measures, prevention of human–bear conflicts, establishment of compensation and funding schemes, stakeholder platforms, and awareness-raising activities. Each thematic chapter combines scientific background, practical recommendations, limitations of current approaches, and policy implications. The document also includes multiple detailed case studies from LECA cross-border and reference areas demonstrating the practical application and effectiveness of specific mitigation measures, monitoring methods, participatory governance approaches, financial mechanisms, and community engagement strategies. Finally, the guidance concludes with a lessons learned section summarising the main risks, governance challenges, and recommendations for strengthening long-term, evidence-based, and participatory coexistence strategies for large carnivores in the Carpathians.

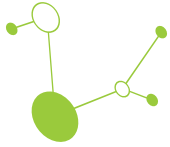

3. Selected best practices from Carpathian cross-border pilot and reference areas in thematic pillar “Conflict prevention”

In line with the strategic objective #3 of the Carpathian Action Plan (Improve coexistence of humans with large carnivores), is to bring effective solutions, mitigation measures and tools to minimise human-carnivore conflict across Carpathians. In this context, we present the selected recommendations and practices that were validated through project activities in cross-border pilot and reference areas. Detailed results on the conflict thematic pillar from these areas can be found in the Output section: <https://www.interreg-central.eu/projects/leca/?tab=outputs>.

A. Identification of human-provided/anthropogenic attractants and hot-spot analyses

Livestock depredation

One of the most challenging and most often mentioned conservation issues associated with large carnivores, especially wolves is livestock depredation, particularly in areas where their long absence has meant that farmers have not maintained or reintroduced husbandry practices designed to prevent damage (Linnell, 2013; Lorand et al., 2022). Livestock depredation by large carnivores can strongly influence stakeholder attitudes in a negative way, which in turn affects the success of conservation efforts (Dressel et al., 2015). In Europe, attitudes toward large carnivores tend to become more negative when people perceive increasing carnivore abundance and a heightened risk of damage (Barmoen et al., 2024; Eriksson et al., 2015). Consequently, maintaining low levels of livestock damages is essential for reducing human–large carnivore conflicts. Achieving this requires robust knowledge of large carnivore distribution, habitat use and the identification of spatial conflict hotspots (Treves et al., 2004) to be able to plan effective conflict prevention strategies.

Probably the simplest and most commonly applied approach is to conduct a general and a spatial analysis of available livestock-damage data across multiple consecutive years to identify areas or specific localities with frequent attacks, using the highest-resolution administrative units possible, such as cadastral parcels or district-level divisions. The advantage of this type of analysis is that such data are typically available from the relevant authorities or organisations. However, the method also has its limitations, as it is inherently dependent on the quality and reliability of the input data. For instance, if farmers have little incentive to report damages (e.g., they are not compensated for the damage), or if clear institutional reporting procedures and systematic data-collection protocols are lacking, the resulting analyses will be unreliable and may underestimate the extent of losses—and consequently the actual level of conflict.

A more refined and recommended approach to identifying conflict hotspots is to complement the above-mentioned analyses with robust monitoring methods, including the use of telemetry and other standard monitoring tools. This integrated approach not only produces high-resolution conflict maps but also helps identify areas where conflicts are likely to occur in the future. As showcased under Case study 1 in the Supplementary Materials, applying these combined techniques. Although these methods are more labour intensive and require greater financial investment, they provide much more detailed and reliable data, supporting the development of effective mitigation strategies and improving the identification of conflict hotspots.

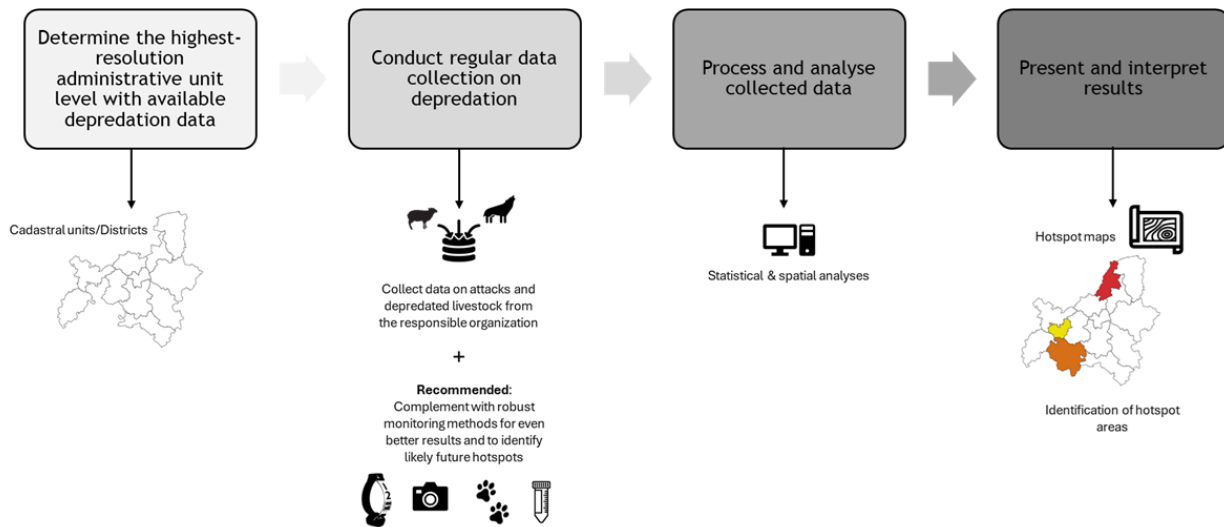
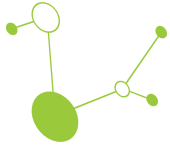

1. Figure – Workflow of the identification of livestock depredation hotspots.

Human-bear conflicts

Human-bear conflicts are diverse but are most often associated with bears' opportunistic foraging and their tendency to exploit easily accessible food sources. Numerous studies from North America (Creachbaum et al., 1998; Herrero et al., 2005; Jope, 1985; Wilson et al., 2006), Asia (Sato et al., 2005), and Europe (Bereczky et al., 2011; Elfström, Davey, et al., 2014; Elfström, Zedrosser, et al., 2014; Swenson, 2000) confirm that easy access to anthropogenic food is a major driver of human-bear conflict and is directly associated with the emergence of “conflict bears” (bears involved in repeated human–bear conflicts, Lackey et al., 2025). Although such individuals typically constitute only a small portion of the population, they account for the majority of human-bear conflicts, while most bears rarely come into conflict at all. Limiting access to anthropogenic, human-produced food is widely regarded as one of the most effective preventive measures, achieving significant reductions in incident rates. Although the identification of these locations of interest can be difficult it is key to prevent the habituation of bears towards humans.

Conflict hotspot zones can be identified indirectly by using available information from responsible authorities and organisations, such as emergency call logs and reports of damage or conflict events. The precise location of anthropogenic attractants can be determined through field mapping carried out by rangers or other responsible personnel, and it is advisable to inspect the immediate surroundings of every conflict event thoroughly. Regular patrols in the vicinity of settlements located in hotspot areas to identify potential conflict sources are also recommended. Patrolling and reporting can also be done in cooperation with informed volunteers recruited among the general public.

Limitation of this approach is that some anthropogenic attractants and their locations may remain hidden for extended periods, allowing bears to become habituated before proper interventions can be implemented. Once bears are regularly approaching settlements, management becomes considerably more difficult compared to preventing such behaviours from developing in the first place. Although it is relying on information that should be already available and tasks that could be integrated relatively easily into the daily job of the responsible personnel.

Even better results can be achieved as was shown in Case study 2 by complementing these methods with telemetry and genetic sampling techniques, although the adoption of these are labour intensive and can require high investment. Since only a few bear individuals are typically taking part in most of the conflict events, and because individual bears are typically visually indistinguishable, targeted collaring of bears involved in human-bear conflicts can contribute to better understanding of their behaviour and produce high-resolution conflict maps.

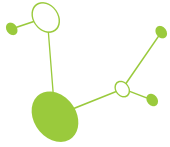

Additionally, the trapping, tranquilising, and collaring process may also act as a form of aversive conditioning, associating proximity to humans with unpleasant stimuli. Regular diet analyses for example, using metabarcoding of faecal samples are also recommended, as they can reveal general trends in the proportion of anthropogenic food in bear diets in the area of interest and help identify individuals that frequently consume food of human origin.

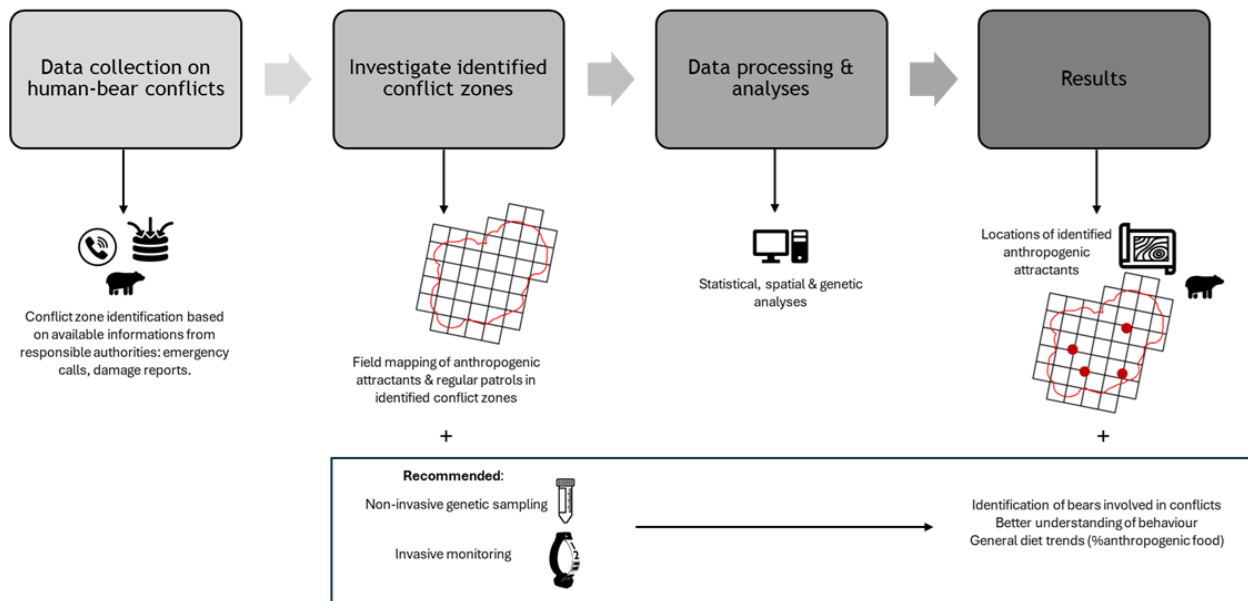

2. Figure – Workflow of the identification of human-bear conflict zones and locations of attractants.

B. Removal of human-provided/anthropogenic attractants and application of prevention measures

Protection of livestock, including beehives

Overall, the most successful damage mitigation measures are operating at the stage of preventing carnivore access to livestock. Experience shows that the most effective results have been achieved through modern electric-fencing techniques, traditional shepherding systems, or certain combinations of the tools of those (Linnell & Cretois, 2018). Traditional European shepherding systems relied on shepherds accompanied by both guarding and herding dogs during daytime grazing, with livestock enclosed in corrals or sheds at night (Lescureux & Linnell, 2014; Linnell & Lescureux, 2015). Although these traditional husbandry practices would still be viable today, the knowledge required to apply them effectively has been lost or abandoned in many regions due to the long absence of large carnivores (e.g., Kikvidze & Tevzadze, 2015). At the same time, the use of shepherds has often become financially unsustainable because of rising labour costs.

Modern predator-proof electric fences are widely regarded as the most effective method for protecting livestock from large carnivores, particularly canids and ursids. They are relatively easy to install and operate. Although shortcomings of such systems are that they are not suitable for all terrain types; steep slopes, irregular ground, and exposed areas can hinder installation and reduce effectiveness (Linnell et al., 2012; Lorand et al., 2022; Oliveira et al., 2021). However, compared with traditional husbandry systems, predator-proof electric fences require higher upfront investment and must be installed correctly. Still, they are easy to use and their maintenance costs are relatively low. But regular checks and proper maintenance - such as keeping vegetation down - are essential to ensure consistent performance (Frank & Eklund, 2017). In countries with high labour costs, the use of

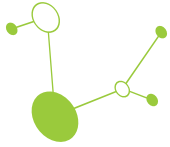

carnivore-proof electric fencing around permanent pastures is likely to be one of the most cost-effective solutions for damage prevention, as demonstrated across multiple EU-funded projects (Linnell & Cretois, 2018).

Nowadays multiple types of electric fence is available for the livestock keepers to protect their animals. Although there is no universally accepted configuration for these fences but according to our and the prior experiences we described the required necessities for them to be effective in the box below for minimum standard measures (Box 1.). Although these systems have already been proven effective, the technical requirements set by the applicable regulations in the Carpathian countries for preventive measures that farmers must meet in order to be eligible for compensation may differ from the minimum technical standards described here. In countries where the condition for compensation eligibility is not precisely defined or only requires that farm animals must be placed in a closed enclosure, it is recommended that the minimum standards for compensation are aligned in the regulations with the described minimum standards for effective protection.

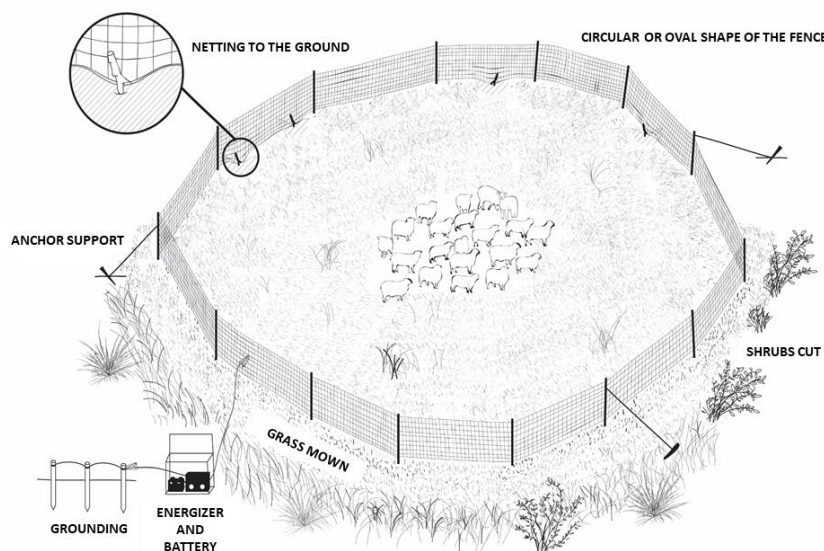

3. Figure – Schematic setup of a properly installed high electric netting to protect livestock from large carnivore depredation (Source: Berce & Černe, 2016).

However, when the electric fences are combined with livestock-guardian dogs, or supervision of shepherds, or other deterrents the effectiveness of the protection measures can even be further enhanced (Linnell et al., 2012; Lorand et al., 2022). These measures are summarised in Box 2. as best practices down below and are tested at multiple project sites including at the Hungarian and Slovak and the Czech and Slovak border showcased in Case study 3.

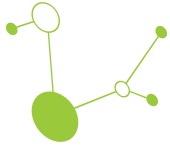

Box 1. - Minimum standard measures to protect livestock

Install **predator-proof electric fencing** around livestock pastures and enclosures.

Use **multi-wire electric fencing systems with at least 5–7 wires**.

Ensure **minimum fence height of 120 cm**.

Maintain a **minimum voltage of 3,000–5,000 V throughout the fence system**.

Position wires correctly:

- lowest wire **<20 cm above ground**
- second wire **≤40 cm**
- third wire **≤60 cm**
- Spacing between the wires up from 60 cm should be at least 30 cm.

Regularly **inspect and maintain electric fences** (e.g., control vegetation, ensure proper voltage).

Use **high electric netting (minimum 145 cm)** where multi-wire fences are impractical or where greater mobility is needed.

Place **livestock in secure night enclosures** (corrals, sheds, or fenced pastures).

Protect **beehives with predator-proof electric fencing** (multi-wire or electric netting).

Align **compensation eligibility criteria with minimum technical protection standards**.

Box 2. - Recommended measures (best practices) to protect livestock

Combine **electric fencing with livestock-guardian dogs** to strengthen deterrence.

Maintain **shepherd supervision during grazing** where feasible.

Apply **traditional shepherding systems** (shepherd + herding dogs + guarding dogs) where economically viable in combination with other modern preventive measures.

Install **fladry along fences** to enhance short-term deterrence, particularly during periods of high predation risk.

Use **additional deterrents such as Foxlights or audiovisual devices** where appropriate.

Ensure **professional guidance or training for farmers** on proper installation and management of protection systems.

Keep **livestock-guardian dogs within fenced areas** to improve effectiveness and reduce conflicts with people or wildlife.

Conduct **regular inspections of deterrent devices** (e.g., fladry integrity, fence voltage).

Adapt protection systems to **local terrain conditions and farm management practices**.

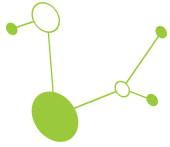

Practices against human-bear conflicts near humans

Bears are opportunistic omnivores and can therefore be easily attracted to anthropogenic food sources, including household waste. Consequently, the primary reason bears approach human settlements is the availability of easily accessible human-derived foods. This behaviour not only causes nuisance and fear among residents but also contributes to behavioural changes in bears through habituation to human presence and conditioning to anthropogenic food. Such individuals progressively lose their wariness of humans and may become regular visitors to settlements, involved in recurrent human–bear conflicts; often referred to as conflict bears.

Although aversive conditioning methods such as acoustic deterrents, non-lethal projectiles or active hazing can be applied in an attempt to reverse such behaviour, results are mixed, and these methods can be costly and labour-intensive. For this reason, limiting access to anthropogenic food sources is the most effective and widely recommended long-term approach to preventing conflicts with bears and their incursions into settlements. This, however, requires a systematic and coordinated strategy. Experience shows that success rates are significantly higher when local communities are actively involved. Effective implementation demands intensive public education on appropriate behaviour in bear habitats and its surroundings, raising awareness about the prevention measures, strict waste-management practices—including the use of bear-proof containers and modified collection systems—removal of illegal dump sites and the prohibition of deliberate feeding of bears. For larger settlements, zoning should be considered. Buildings located closer to forests should be subject to strict waste management regulations and the complete elimination of other attractants (e.g., fruit trees and other crops attractive to bears). For smaller settlements, regulations should be implemented throughout their entire area. Necessary and best practices were identified and summarised in Box 3. and Box 4. to prevent human-bear conflicts and showcased in Poland in Case study 4.

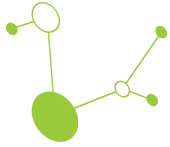

Box 3. - Minimum standard measures to reduce human-bear conflicts

Prevent access to anthropogenic food sources in settlements and surrounding areas.

Implement **strict waste-management practices** in bear habitats and its vicinity.

Install and use **bear-proof waste containers** for household waste.

Adapt **waste collection systems** to minimise access by bears (secure storage and timely collection).

Remove illegal dump sites and uncontrolled waste disposal areas.

Prohibit intentional feeding of bears and enforce regulations against it.

Conduct **public education and awareness programmes** on appropriate behaviour in bear habitats.

Protect beehives and chicken yards with predator-proof electric fencing (multi-wire or electric netting).

Establish **clear municipal regulations on waste handling** in settlements within bear habitats.

Box 4. - Recommended measures (best practices) to reduce human-bear conflicts

Engage local communities actively in planning and implementing conflict-prevention measures.

Develop **coordinated, systematic strategies** involving municipalities, NGOs, and scientific institutions.

Apply **zoning approaches in larger settlements**, with stricter waste and attractant management near forest edges.

Remove or manage bear attractants near settlements (e.g., unprotected fruit trees, crops).

Establish **multi-stakeholder cooperation platforms or working groups** focusing on communication and waste management.

Implement **rapid-response teams for bear incidents** (e.g., Bear Emergency Teams).

Use **monitoring and early-warning technologies** (e.g., GPS collars, real-time alert systems, monitoring platforms).

Develop **mobile applications or digital tools** to inform residents about bear presence and safety measures.

Conduct **communication and outreach campaigns** through social media, videos, and educational materials.

Organise **public awareness events, festivals, or visitor centres** promoting coexistence with bears.

Use **participatory planning processes** to co-develop conflict-management solutions with stakeholders.

Deploy **aversive conditioning methods** (e.g., acoustic deterrents, hazing) when necessary, though primarily as supplementary tools.

Promote **“Bear-Smart community” models** integrating prevention, technology, stakeholder cooperation, and education.

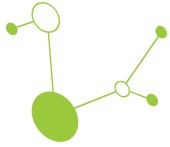

C. Establishment and using of funding and compensation schemes

Prevention and compensation schemes represent key components of damage-mitigation and conflict-management policies in many countries where large carnivores occur. However, these schemes vary considerably across Europe, and—according to our findings—even neighbouring Carpathian countries show substantial differences in how such measures are designed and implemented.

	Compensation schemes	Prevention schemes	Support for additional costs & extra work
Czechia	✓	✓	✓
Hungary	✗	(✗)*	✗
Poland	✓	(✓)**	✗
Romania	✓	✓	✗
Slovenia	✓	✓	✓
Slovakia	✓	✗	✗
Ukraine	✗	✗	✗

1. Table - Existence of operation schemes and support systems in the LECA countries. *Hungary currently lacks a permanent, systematic scheme for conflict-prevention. In the earlier years, however, the government allocated funds via NGOs and National Park Directorates to supply farmers with preventive measures, including electric fencing and livestock-guardian dogs. **Poland does not operate a unified, nationwide prevention programme. Instead, preventive measures are implemented separately by Regional Directorates for Environmental Protection and National Parks, leading to region-specific differences.

The underlying assumption is that providing financial compensation for depredation, together with support for implementing preventive measures, increases farmers’ tolerance toward large carnivores. Since large-carnivore-related damages often affect farmers unequally—both at broader regional scales and even within the same locality—these schemes aim to provide more equitable conditions by supporting those who bear the costs associated with conserving large carnivores and the ecosystem services they provide. Nevertheless, the effectiveness of compensation and prevention programmes depends heavily on the socio-economic and cultural context (MacLennan et al., 2009).

Concerns have been raised about the implementation of economic support mechanisms, particularly when they are introduced without proper stakeholder involvement. Compensation schemes are expensive; they require a proper and quick validating and processing system for claims with clear protocols and trained personnel in addition to the amounts paid. It is often argued that compensation schemes, when applied in isolation, may unintentionally reward passivity and fail to encourage farmers to adopt effective mitigation strategies (Nyhus et al., 2005; Bulte & Rondeau, 2006).

For this reason, it is generally recommended that compensation be made conditional upon the adoption of adequate livestock-protection measures. However, as the implementation of such preventive actions often requires substantial financial investment from farmers, dedicated support schemes are essential. Evidence suggests that tolerance improves and long-term conflict is most effectively reduced when compensation and preventive measures are implemented simultaneously (Bautista et al., 2019). Furthermore, funding for these measures must be predictable, reliable, and continuous in order to ensure sustained effectiveness and stakeholder trust.

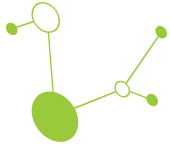

The costs of preventive and compensatory measures can be covered by either national budgets or EU funds, depending on the specific measure. Within the EU, CAP funding is widely used to support prevention, and typically covers two main types of assistance:

1. Investment support for livestock-protection infrastructure, and
2. Compensation for the additional labour required to operate and maintain these protective measures.

In contrast, damage compensation payments must be financed from the state budget. However, financial support alone does not ensure effective outcomes. Without mechanisms that provide farmers how to apply for these funds, with practical guidance on how to correctly implement subsidised preventive measures—and without systems to verify their proper use—these investments may fail to deliver the expected level of protection.

Recommended best practice for economic support mechanisms includes not only funding preventive measures and compensating damages, but also covering the ongoing additional costs and extra workload associated with the presence of large carnivores—such as the care and feeding of livestock-guardian dogs, as illustrated by the system currently operating in the Czech Republic (see Case Study 5). Furthermore, an institutionalised advisory and monitoring framework is essential, providing technical guidance, overseeing implementation, and ensuring that feedback from farmers is systematically collected and incorporated into management decisions.

Box 5. - Minimum standard measures how to manage conflicts with financial instruments

Establish **formal compensation schemes for damages caused by large carnivores** (e.g., livestock losses).

Ensure **clear protocols for claim verification, validation, and processing**.

Maintain **trained personnel and administrative systems** to assess and process compensation claims.

Provide **financial support for preventive livestock-protection measures** (e.g., fencing, livestock-guardian dogs, night enclosures).

Ensure dedicated funding sources for prevention and compensation measures (national budgets and/or EU funds).

Use **CAP or similar funding instruments** to support investments in livestock-protection infrastructure.

Define **eligibility criteria and technical standards** for subsidised preventive measures.

Establish **legal frameworks regulating compensation for damage caused by protected species**.

Ensure **predictable, reliable, and continuous funding** for compensation and prevention programmes.

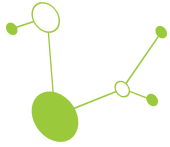

Box 6. - Best practices how to manage conflicts with financial instruments

Make **compensation conditional on the adoption of adequate preventive measures**.

Implement **prevention and compensation schemes simultaneously**, rather than separately.

Ensure **active stakeholder involvement** in the design and implementation of economic support schemes.

Provide **institutionalised advisory systems** offering technical guidance on preventive measures.

Establish **monitoring and verification systems** to ensure proper implementation of subsidised measures.

Offer **practical assistance to farmers in applying for financial support schemes**.

Support **additional operational and extra labour costs associated with coexistence**, such as maintaining livestock-guardian dogs.

Compensate **additional management restrictions in areas of repeated carnivore occurrence** (e.g., grazing limitations).

Collect and integrate **systematic feedback from farmers to improve** programme effectiveness.

Ensure **coordination between EU funding instruments and national** compensation mechanisms.

Promote **transparent and efficient administrative procedures** to maintain stakeholder trust.

Adapt schemes to **local socio-economic and cultural contexts** to improve tolerance toward large carnivores.

D. Establishment and operation of local/regional/cross-border stakeholder platforms

In 2014, the European Commission established the EU Platform on Coexistence between People and Large Carnivores with the aim of reducing conflicts related to large carnivores. The Platform was intended to facilitate high-level exchange of issues, experiences, and perspectives among stakeholders. However, members quickly recognised that conflicts vary widely across regions due to socio-economic, cultural, and ecological differences. As a result, the EU Platform supported the creation of regional and local platforms that could better address context-specific needs and challenges.

Such platforms—or similar multi-stakeholder mechanisms—now operate in many parts of Europe. Their main purpose is to bring together diverse stakeholder groups in a constructive environment to exchange knowledge, share good practices in large carnivore conservation and management, minimise human–carnivore conflicts, and distribute relevant information among their members. These platforms can help ensure that those who bear the greatest costs of coexistence are recognised and their concerns acknowledged, while also providing a safe space for constructive dialogue, peer-to-peer learning, and direct feedback.

Because conflict mitigation tends to be more effective when stakeholders are actively involved, these inclusive mechanisms represent a shift from traditional top-down governance arrangements toward more participatory approaches in natural resource management. Ideally, such participatory structures enhance both the legitimacy and the effectiveness of conflict-prevention measures and the broader policy outcomes derived from them.

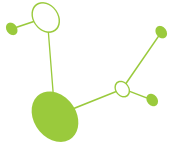

Setting up the platforms: The bottom-up foundation

To ensure the legitimacy and effectiveness of conflict-prevention measures, the establishment of these platforms must strictly adhere to a bottom-up model. This principle dictates that platforms avoid creating artificial structures, redundant competencies, or unrealistic expectations that do not align with local realities. Instead, they should emerge from a thorough initial stakeholder analysis. This process begins with a detailed breakdown of target groups directly affected by human-wildlife conflict to ensure those bearing the greatest costs are recognised.

A critical component is power mapping to differentiate roles: identifying who provides financing, who holds decision-making authority, and who acts as the primary implementer ("who pays, who decides, who does?"). Furthermore, the area of concern must be redefined, as functional conflict zones often transcend existing administrative boundaries or strictly ecological areas.

Before formal plenary sessions involving all stakeholder groups, the process requires an introductory phase of "formative workshops" held among uniform peer groups—such as environmentalists, affected land users (herders, hunters), and law enforcement. These workshops allow peer groups to clarify their specific goals, objectives, and grievances in a safe environment, effectively pre-identifying potential conflict points and unifying interests before entering broader multi-stakeholder negotiations.

Operationalising platforms: From dialogue to action

Once the foundation is laid through formative meetings, the platform moves into its operational phase by holding initial plenary sessions. These sessions should be established based on pre-defined cross-cutting topics identified during the introductory phase. To foster cooperation mechanics, the platform should prioritise identifying achievable solutions that build trust among diverse stakeholders. This operationalisation can be managed either through a series of addressed negotiations or by establishing specialised work-groups and task forces designed to tackle the specific problems raised by peer groups.

The focus of these working groups is the clear formulation and pursuit of action points and realistic goals. By shifting from high-level exchange to context-specific problem-solving, the platform transforms into a functional mechanism for peer-to-peer learning and direct feedback. Consistent follow-up on these action points is essential to maintain the momentum of the participatory approach and ensure that the concerns of all members are addressed constructively. This structured transition from peer-group discussion to multi-stakeholder implementation ensures that the resulting policy outcomes are both practical and locally supported.

E. Raising awareness and active involvement of stakeholders to prevent conflicts

Knowledge, education, and awareness-raising play an important role in preventing conflicts with large carnivores. In general, people with greater knowledge about carnivores tend to hold more positive attitudes toward them (Ericsson & Heberlein, 2003; Trajçe et al., 2019). They are also more likely to adopt behaviours that reduce the risk of conflict, such as avoiding practices that habituate carnivores to human-derived food and applying appropriate livestock-protection measures.

However, while education and awareness-raising are valuable mitigation tools, relying on them alone has limitations when trying to influence people's attitudes, values, or behaviour. Wildlife-related values often form early in life and remain relatively stable over time (Bright & Manfredi, 1996; Bruskotter et al., 2007). As a result, educational interventions by conservation practitioners may have limited impact on deeply held attitudes toward large carnivores (Dickman et al., 2013).

The recommended approach, therefore, is to ensure the provision of permanent, easily accessible, and regularly updated information—for example on municipal websites—regarding proven preventive methods for reducing

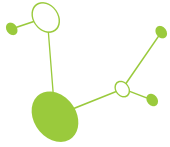

conflicts with large carnivores. Regular information campaigns should target residents and tourists, and especially livestock and beekeepers, hoteliers, and restaurateurs. Everyone living near large carnivores should know how to avoid encounters, how to prevent attracting carnivores to settlements, and how to react in the event of a direct confrontation. In addition, the topic of large carnivores should be more strongly integrated into hunter-training programmes and the university curricula of natural resource managers.

Although awareness-raising, practical tools, and economic interventions have been the dominant approaches to mitigating human–large carnivore conflicts over recent decades, these strategies have limitations. Many conflicts associated with large carnivores are social conflicts—rooted in values, cultural identities, power relations, and divergent worldviews—rather than solely in the presence or behaviour of the animals themselves (Madden, 2008; Teel & Manfredi, 2010). In this sense, conflict can be understood as a situation in which different stakeholder groups hold divergent or competing views regarding the presence and/or management of large carnivores (Redpath et al., 2013). This perspective shifts the analytical focus from direct human–carnivore interactions to the human–human dimensions of conservation and wildlife governance (Salvatori et al., 2020).

Accordingly, stakeholder engagement through participatory processes has become an increasingly important best practice for mitigating such human–human conflicts. Mechanisms such as regional dialogue platforms or practical forms of collaboration—such as early hands-on experiences for students or joint participation in large carnivore monitoring—can strengthen mutual understanding and cooperation. These approaches not only enhance inclusiveness but also build trust, foster constructive relationships among stakeholder groups, improve understanding of carnivore ecology and population dynamics, and ultimately support greater acceptance of jointly developed management decisions.

Such an approach was followed in multiple cross-border pilot areas including the Slovak-Karst and North Hungarian Mts. pilot, where almost one third of the camera traps were operated by hunters, game managers and foresters contributing directly to the monitoring efforts of the project and fostering new professional networks and a shared sense of ownership over both the data generated and the management measures derived from them, thereby reinforcing cross-sectoral cooperation and long-term commitment to evidence-based carnivore conservation.



4. Figure - Installation of a camera trap by a game manager of the EGERERDŐ Forestry Company in the Bükk within the Slovak-Karst & North Hungarian Mts. pilot area.

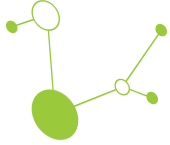

Box 7. - Minimum standard measures in awareness raising and involvement of stakeholders

Establish **multi-stakeholder dialogue platforms** to address conflicts related to large carnivores.

Ensure **representation of key stakeholder groups**, particularly those most directly affected by human-wildlife conflicts.

Conduct **initial stakeholder analysis** to identify affected groups, interests, and potential conflict areas.

Apply **power mapping** to clarify roles and responsibilities among stakeholders (e.g., who finances, decides, and implements actions).

Define the **functional area of concern** for conflict management, recognising that conflict zones may extend beyond administrative or ecological boundaries.

Organise **formative workshops within peer groups** (e.g., farmers, conservationists, hunters, authorities) before multi-stakeholder meetings.

Hold **plenary platform meetings** bringing together all stakeholder groups to exchange information and perspectives.

Provide **regular and accessible public information** on large carnivore presence, behaviour, and prevention measures (e.g., municipal websites).

Implement **public awareness campaigns** targeting residents, tourists, and professional groups affected by large carnivore presence.

Ensure that **education and training programmes** for relevant professions (e.g., hunters, natural resource managers) include information on large carnivore ecology and conflict prevention.

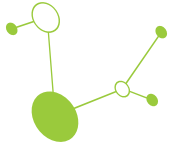

Box 8. - Best practices in awareness raising and involvement of stakeholders

Develop **regional or local coexistence platforms** tailored to the socio-economic, cultural, and ecological context.

Ensure that platforms follow a **bottom-up approach**, avoiding artificial governance structures and aligning with local realities.

Use **participatory planning processes** to co-develop solutions with stakeholders.

Establish **specialised working groups or task forces within platforms** to address specific conflict issues.

Focus platform activities on **practical action points and realistic solutions** rather than solely on information exchange.

Maintain **continuous follow-up and monitoring of agreed actions** to sustain stakeholder engagement and trust.

Promote **peer-to-peer learning and knowledge exchange** among stakeholders.

Facilitate **direct involvement of stakeholders in monitoring and conservation activities** (e.g., camera-trap monitoring programmes).

Encourage **hands-on educational opportunities for students and practitioners** in wildlife monitoring and management.

Strengthen **cross-sector cooperation and professional networks** among conservationists, hunters, land managers, researchers and other relevant stakeholders.

Integrate **communication and outreach activities** that explain both ecological aspects of carnivore conservation and practical prevention measures.

Recognise and address the **social dimensions of conflicts**, including cultural values, identities, and power relations among stakeholder groups.

Promote **long-term trust-building and mutual understanding** between stakeholders through inclusive and transparent dialogue processes.

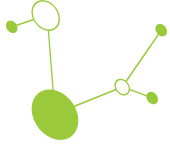

4. Case studies from LECA Cross-border and Reference Areas

Case study 1: Identification of livestock depredation hotspots in the Beskydy-Kysuce pilot area

Spatial analysis of livestock-damage records across consecutive wolf years was conducted and complemented by monitoring techniques (camera trapping and genetic sampling) to identify conflict hot spots and better understand livestock-depredation trends along the Czech–Slovak border. Two wolf years (1 May–30 April), 2023/24 and 2024/25, were examined. Across this period, 140 wolf attacks were recorded in the Beskydy–Kysuce area, with the majority of incidents (88%) occurring on the Czech side.

In 2023/24, damages were concentrated in areas of intensive grazing—particularly the Silesian Beskids, Jablunkovské mezihoří, and the Vsetínská Bečva valley—which overlapped with three territories where wolf reproduction was confirmed.

In 2024/25, incident numbers declined sharply (from 100 to 40), with the most pronounced reduction in the Silesian Beskids. Monitoring data helped clarify this trend by revealing a shift in the local breeding pair, suggesting that changes in pack composition may have reduced livestock predation. A similar decline in the Vsetínská Bečva valley coincided with the disappearance of local packs following the loss of breeding individuals.

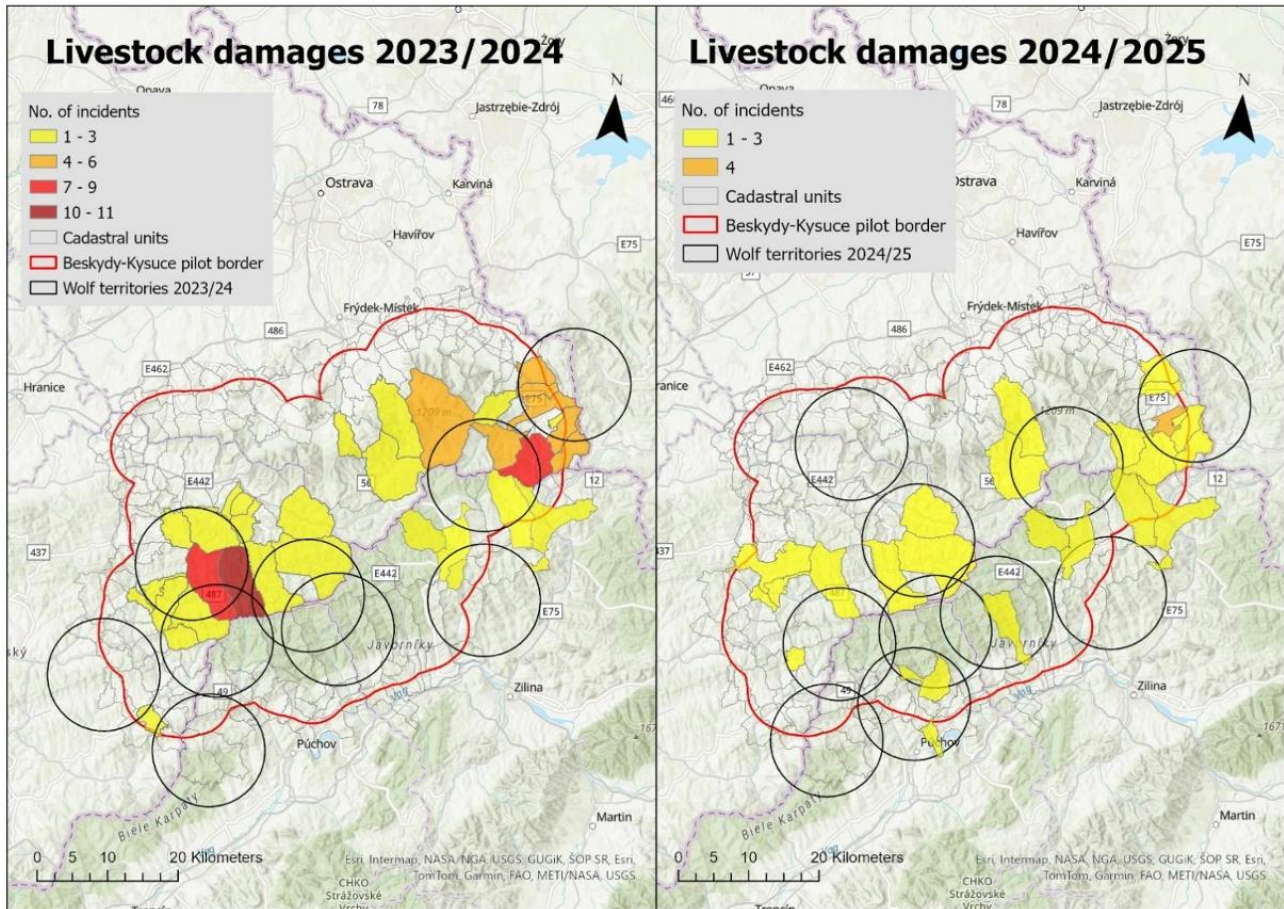
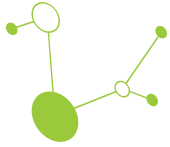

5. Figure - Distribution and number of wolf attacks in the Beskydy-Kysuce pilot area in the two consecutive wolf years (2023/24 and 2024/25) complemented with the localised wolf territories based on monitoring results, at the scale of cadastral units.

Long-term trends reveal structural vulnerabilities

Analysis of eight wolf years (2017–2024) revealed 452 depredation events and 1,610 livestock killed, with 93% of all attacks occurring in the Czech part of the pilot area. Sheep represented the majority of losses. Three cadastral units—Horní Bečva, Nýdek, and Bukovec u Jablunkova—accounted for more than a quarter of all attacks and livestock losses.

On the Slovak side, most incidents were concentrated in Korňa, Raková, and Turzovka, where long-standing inadequate protection (low fences, poor electric fencing parameters, absence of livestock-guarding dogs) allowed recurring wolf attacks year after year.

Spatial clusters of repeated incidents were also identified in the Vsetínská Bečva valley, the Silesian Beskids, and Jablunkovské mezihoří, again largely linked to insufficiently protected pastures.

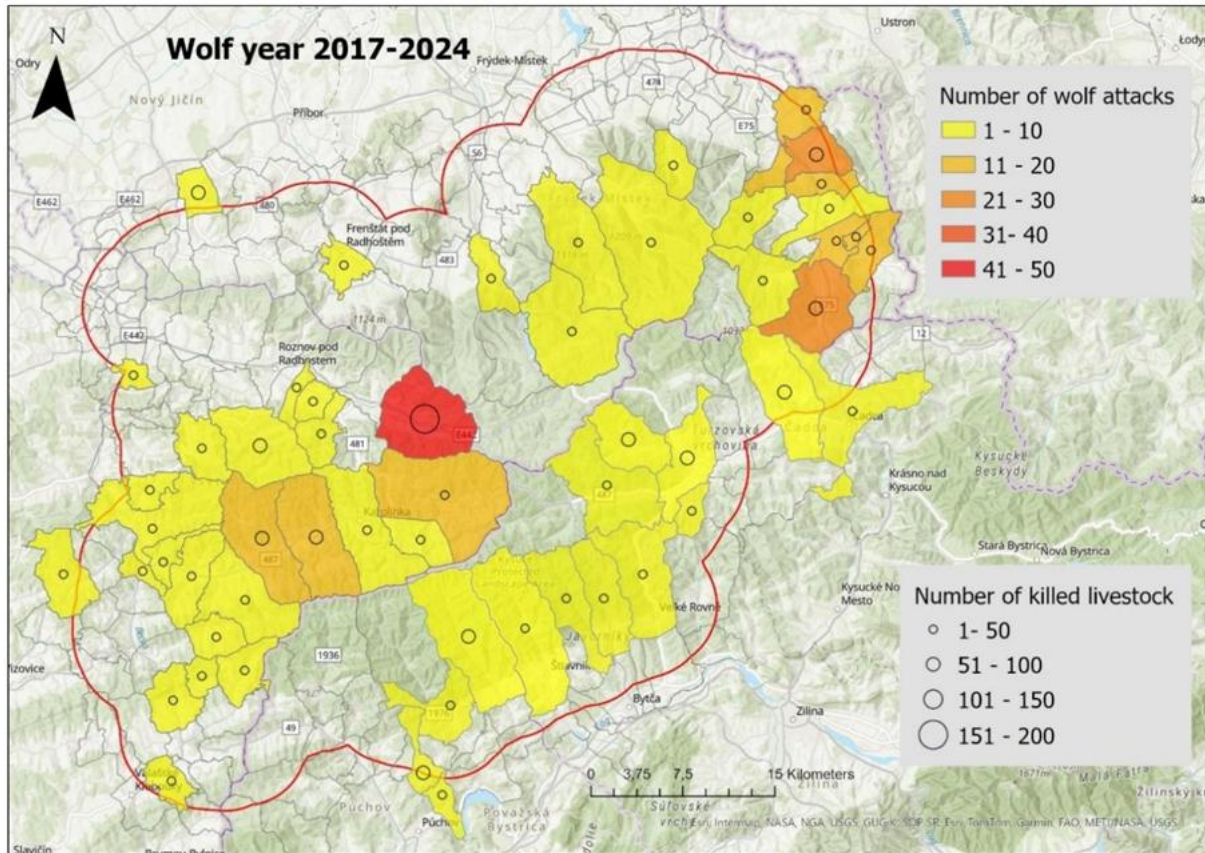
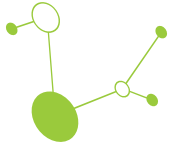

6. Figure – Distribution and number of wolf attacks as well as number of killed livestock in the Beskydy-Kysuce pilot area over eight consecutive wolf years following the establishment and development of the wolf population, at the scale of cadastral units.

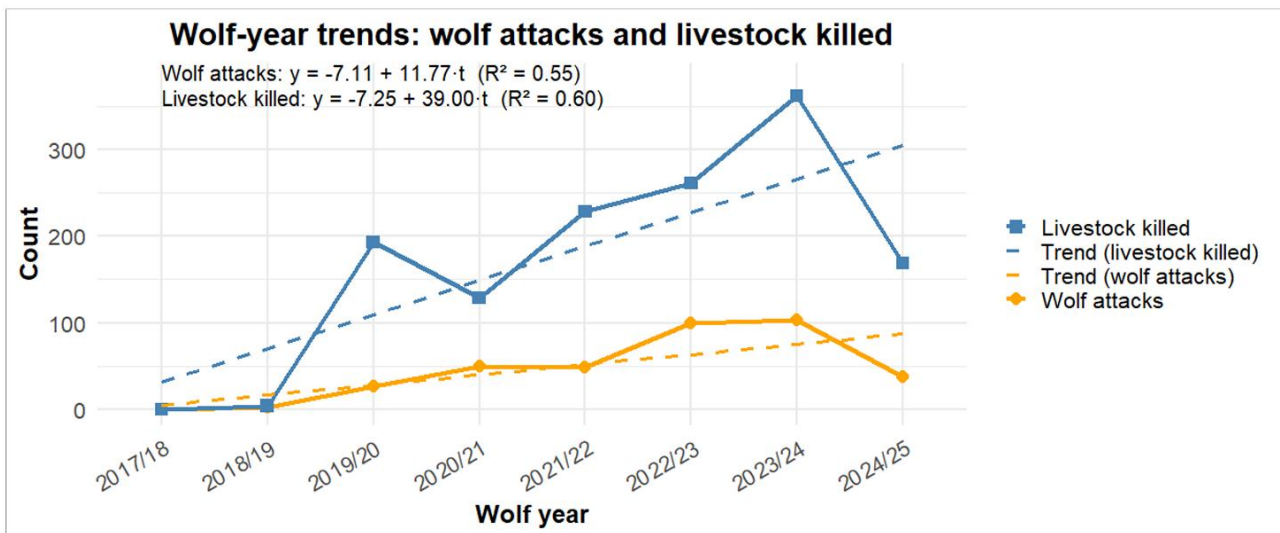

7. Figure - Annual number of wolf attacks (orange line) and livestock killed (blue line) from the wolf years 2017/18 to 2024/25. Dashed lines show linear trend lines with corresponding regression equations and coefficients of determination (R^2).

Implications for conflict management

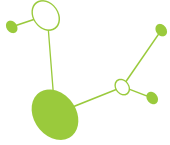

Despite annual variability, both the number of attacks and livestock losses showed a clear long-term increase, with livestock losses rising faster indicating more animals killed per incident, consistent with surplus killing. The decrease in 2024/25 may reflect short-term fluctuations or early effects of improved preventive measures, but further years of data and more robust analyses are needed to confirm this trend.

Key takeaway

The integration of spatially explicit livestock-damage data over multiple years with systematic monitoring of wolf packs enabled the identification of persistent hot spots, clarified the role of pack dynamics in depredation patterns, and highlighted areas where preventive measures were insufficient. This combined approach provides a strong evidence base for targeted, region-specific mitigation strategies.

Case study 2: Identification of attractants related to human-bear conflicts in the Tatra pilot area near Zakopane

Food conditioning, when bears learn to obtain anthropogenic food by overcoming their natural wariness, is a major driver of human-bear conflicts. In the highly visited Tatra region, where millions of tourists increase recreational pressure each year, this problem intensifies especially around foothill settlements and tourist resorts. In the Polish Tatras, repeated conflicts are closely linked to unsecured waste and other human derived food sources, including items deliberately provided to attract bears.

Methods

From 2023 to 2025, 16 bears suspected of involvement in human-caused conflicts were captured and fitted with GPS collars, including five with video capability, to examine their behaviour, habitat use, and the potential role of anthropogenic attractants as drivers of conflict. Collars recorded roughly 12 locations per day, with increased fix rates triggered by virtual fences whenever individuals entered towns or settlements. GPS clusters were systematically field-checked to identify attractants, and faecal samples collected at these sites were analysed using metabarcoding. Of 76 collected samples, 66 samples from 8 individuals were suitable for dietary analysis. Bears were classified into two categories: “non-conflict bears” individuals visiting the settlement only occasionally and “conflict bears” visiting the settlement frequently.

Findings

Field verification showed that bears repeatedly entered settlements due to unsecured garbage, carcass dumping in nearby woodlands, and intentional feeding for activities such as wildlife photography.

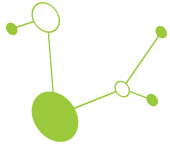

8. Figure – Red dots represent bear occurrence in the area surrounding Zakopane at the foot of Polish Tatra Mountains. The pictures illustrate some of the locations, including places with human-provided food attractants and natural beech forest.

Diet analysis revealed 88 taxa (56 plants, 24 insects, 6 vertebrates), with plants dominating the diet (mean 5.6 taxa/sample, 96% containing >1 taxon). Common items included *Urtica dioica* (24%), *Vaccinium myrtillus* (15%), *Luzula sylvatica* (14%), carpenter ants, wasps, and vertebrates such as wild boar (10.6%), Caprinae (7.6%), red deer (6.1%), and domestic chicken (6.1%).

Conflict bears had less diverse diets (mean 4.9 vs. 5.9 taxa) and a much higher share of anthropogenic food (48.3% vs. 19.6%), demonstrating stronger dependence on human-derived resources.

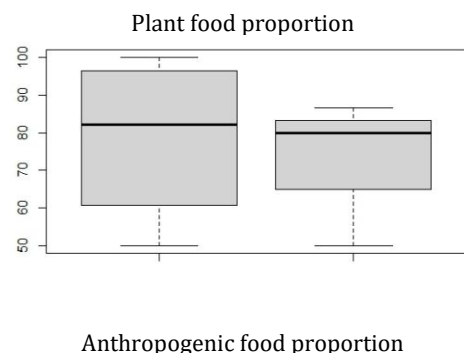

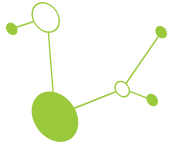

Key takeaways

Food conditioning driven by unsecured waste and other attractants is the primary cause of repeat human–bear conflicts in the Tatra region. Telemetry and diet metabarcoding confirmed that frequently visiting “conflict” bears rely more heavily on anthropogenic food and show lower dietary diversity than occasional visitors, enabling precise identification of attractants and high-risk areas. Improving waste management, enforcing carcass disposal rules, and eliminating intentional feeding - guided by telemetry hotspots - provides the most effective pathway for reducing conflicts in a proactive way.

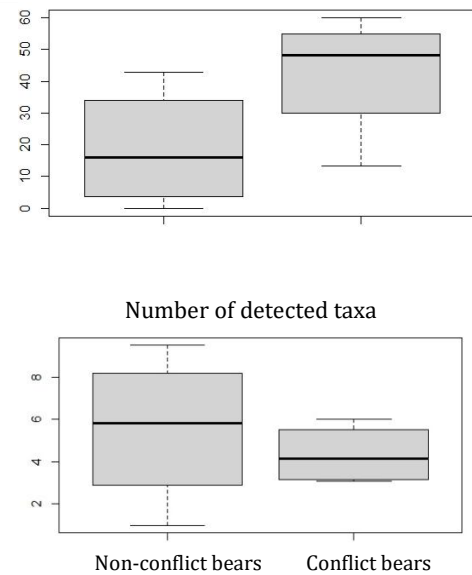

9. Figure – Results of the diet analysis

Case study 3: Implementation of preventive measures to protect livestock in the Slovak Karst & North Hungarian Mts. & Beskydy-Kysuce pilot areas

Within the cross-border pilot area of the Slovak Karst & North Hungarian Mountains, the LECA project tested and validated a combination of preventive tools aimed at reducing wolf depredation on small-scale farms. The intervention focused on a traditional family-run sheep farm in Nekézseny, managing 400 Ile-de-France sheep under extensive grazing.

Implemented measures

The protective system combined several complementary elements:

- Multi-wire electric fencing (120 cm, five-wire) installed around the farmstead and night enclosures (5 ha), enhanced with a visibility band for improved deterrence.
- Livestock-guarding dogs (LGDs) allowed to patrol freely inside the fenced area, providing constant presence and vigilance.
- Herding dogs and human supervision during daytime grazing on nearby pastures.

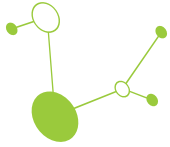

- Foxlights as an additional visual deterrent at the meeting points of the fence and game trails.
- Professional guidance for the farmer on strengthening the overall protection system and managing the equipment effectively.

Results

Throughout the project period, no depredation events occurred despite the presence of large carnivores in the wider landscape. The farmer reported:

- increased sense of security,
- reduced fear and stress linked to livestock protection,
- overall satisfaction with the combined protection system.

The case highlighted that the integration of well-installed electric fencing and adequately trained LGDs can significantly enhance livestock safety even in high-risk areas.



10. Figure – Multi-wire electric fence system installed in Nekézseny, within the Slovak-Karst & North Hungarian Mts. pilot area.

Additional observations from the Beskydy–Kysuce pilot area

A complementary set of trials was conducted in the Beskydy–Kysuce region, where at multiple farms fladry was tested alongside standard electric netting (120 cm), with or without LGDs, and in some cases supported by audiovisual deterrents.

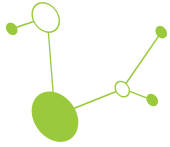

Results

- No livestock depredation occurred at any of the farms where these tools were implemented, even in confirmed wolf territories (through GPS telemetry).
- Farmers appreciated fladry's rapid deployment and ease of installation on flat pastures.
- Effectiveness depended on:
 - regular maintenance,
 - careful installation in windy or uneven terrain,
 - timely replacement of tangled or damaged strips.

Because fladry is not widely manufactured in Europe, availability and cost remain limiting factors. Given its short-term effectiveness, it is best suited for crisis interventions or as a temporary measure until long-term solutions—such as permanent electric fencing—are established.

Key takeaways

Integrated protection combining electric fencing, livestock-guarding dogs, and regular supervision prevented all depredation events in both pilot areas. Fladry proved useful as a rapid, short-term measure, while properly installed predator-proof electric fencing combined with LGDs and other elements of traditional husbandry remains the most reliable long-term solution for livestock. Overall, participating farmers reported increased confidence and satisfaction with the implemented systems.

Case Study 4: Strengthening preventive measures and community engagement in the Bieszczady region

Long-term coexistence between humans and large carnivores depends heavily on community acceptance, which increases significantly when conflict risks are effectively reduced. Since 2013, WWF Poland has supported this effort by systematically providing preventive tools to livestock owners and beekeepers, while also improving waste-management practices in bear-prone areas.

Implemented measures

WWF Poland has distributed 419 electric-fence sets for livestock protection and 181 sets for safeguarding apiaries, in addition to supplying 130 bear-proof waste containers to municipalities. In 2025, the organisation financed more than half of all electric fences delivered to breeders in Poland.

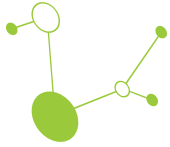

11. Figure – Deployed bear-proof containers in the Polish side of the East Carpathian pilot area

Within the Polish section of the LECA pilot area (2023–2025), 33 electric fences were purchased to protect apiaries (including 3 financed by LECA) and 12 electric fences were acquired for livestock protection (3 funded by LECA). Furthermore, 41 bear-proof waste containers were delivered, with 3 units provided through the LECA project.

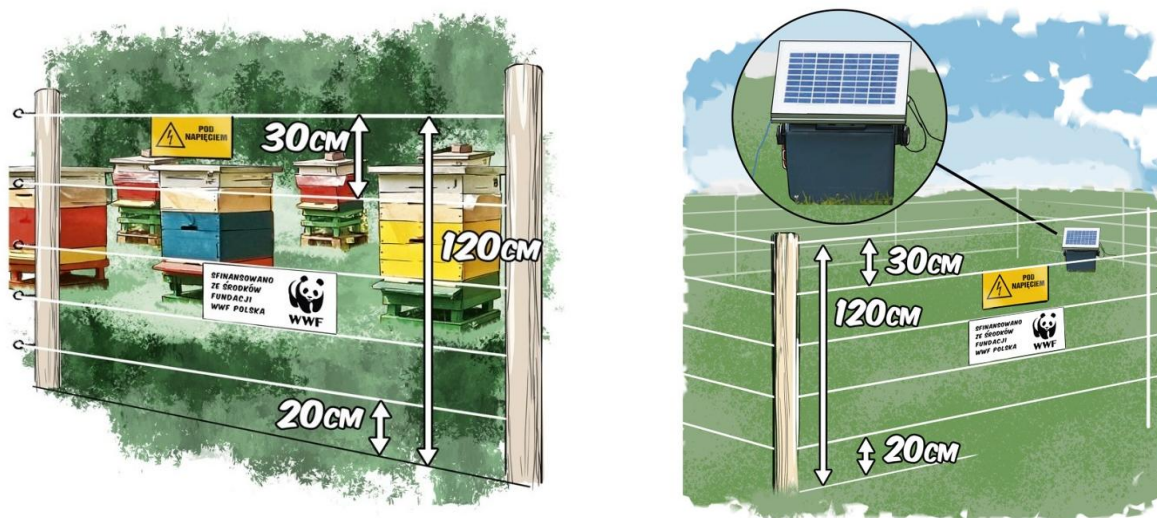

12. Figure – Schematic illustration about the installed protection measures in the Polish side of the East Carpathian pilot area

Evaluation and outreach

To assess effectiveness, interviews were conducted with a livestock farmer and a beekeeper who received LECA-funded equipment. Both reported high functionality and a clear reduction in bear-related risks. These testimonials were disseminated through WWF Poland’s communication channels, complemented by an instructional video demonstrating proper use and maintenance of bear-proof containers, thereby supporting the standardisation of best practices.

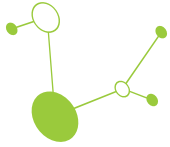

Strengthening cooperation

A major achievement of the LECA project was the enhancement of cooperation among WWF Poland, local governments in the Bieszczady area, and scientific institutions such as the Institute of Nature Conservation and the Polish Academy of Sciences. Guided by the Conflict to Coexistence framework, their collaboration resulted in the formation of thematic working groups focusing on communication and waste management, both identified as key elements in reducing human–bear conflict.

Key takeaways

Preventive measures—particularly electric fencing and bear-proof waste management—proved highly effective, with users reporting reduced conflict risk and strong satisfaction. Coordinated action among NGOs, local authorities, and researchers strengthened regional capacity for long-term conflict mitigation. Enhanced communication and standardised practices helped increase public awareness and support for coexistence.

Case study 5: Best-practice example: Financial support mechanisms for livestock breeders in the Czech Republic

This example provides an overview of the key financial instruments available in the Czech Republic to support coexistence with large carnivores, with a particular focus on livestock protection and related compensation mechanisms. It summarises (1) subsidy-based support for preventive measures, (2) compensation for damage caused by selected specially protected species, and (3) compensation for restrictions on agricultural management in areas of repeated wolf occurrence. Together, these tools form the core framework through which Czech authorities aim to reduce conflict risks, support livestock breeders, and ensure practical implementation of preventive standards in the field.

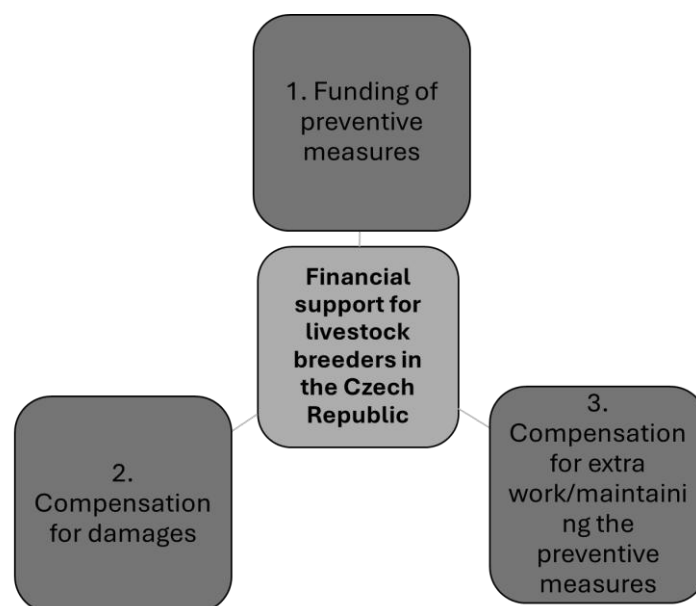

13. Figure – Schematic visualisation of the financial support for livestock breeders in the Czech Republic.

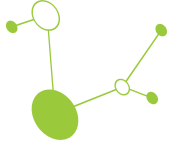

Funding for preventive measures to protect livestock

Financial support for preventive measures to protect livestock against attacks by large carnivores is provided under the Operational Programme Environment 2021–2027 (OPE). The programme is co-financed by the European Union and the state budget of the Czech Republic.

The scheme is administered by:

- the State Environmental Fund of the Czech Republic for business entities (professional farmers), and
- the Nature Conservation Agency of the Czech Republic for non-business entities (small-scale or hobby farmers).

The relevant support scheme is titled Protection of Livestock against Attacks by Large Carnivores. It provides financial assistance for the implementation of preventive measures such as fencing, livestock guarding dogs, night enclosures, and other technical or organisational measures that reduce the risk of attacks by large carnivores (e.g., wolf, lynx, bear).

As this is an EU-funded subsidy scheme, applicants must meet the eligibility criteria and comply with the technical standards and administrative requirements set out in the programme rules. Financial support may cover up to 100% of eligible costs, depending on the applicant category and specific conditions of the call.

Compensation scheme for damages

Compensation for losses resulting from restrictions on agricultural management is granted under Section 58 of Act No. 114/1992 Coll., on Nature and Landscape Protection. This instrument applies specifically to limitations on grazing in areas of repeated wolf occurrence.

The scheme is funded from the state budget of the Czech Republic. It compensates livestock breeders for the increased costs associated with grazing in wolf occurrence areas, particularly the additional expenses linked to maintaining preventive measures. Eligible costs may include, for example, more frequent mowing of vegetation under and around fences, more frequent checks of livestock, and the costs of caring for livestock guarding dogs.

An area of repeated wolf occurrence is a formally designated area in the Czech Republic where the presence of wolves has been repeatedly confirmed. Only within these designated areas may livestock breeders apply both for financial support for preventive measures under the Operational Programme Environment and for compensation for restrictions on grazing.

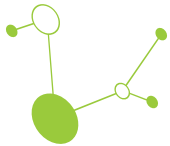

SPPK E 02 006 OCHRANA HOSPODÁŘSKÝCH ZVÍŘAT PŘED ÚTOKY VELKÝCH ŠELM

STANDARDY PÉČE O PŘÍRODU A KRAJINU		
SPECIALNÍ OPATŘENÍ DRUHOVÉ OCHRANY	OCHRANA HOSPODÁŘSKÝCH ZVÍŘAT PŘED ÚTOKY VELKÝCH ŠELM	SPPK E 02 006: III. REVIZE 2024
ŘADA E		
<p>Livestock Herd Protection against Large Carnivore Attacks Schutz von Nutztieren gegen große Raubtiere</p> <p>Tento standard popisuje jednotlivá preventivní opatření na ochranu hospodářských zvířat před útoky velkých šelm.</p> <p><i>Použití zdroje:</i></p> <p>Empfehlungen zum Schutz von Weidetieren und Gehegewild vor dem Wolf [online]. In: Bad Godesberg, 2019, s. 14 [cit. 2019-11-18]. ISBN 978-3-89624-267-9. Dostupné z: https://www.fhn.de/fileadmin/BIN/Service/Dokumentation/Skript530.pdf</p> <p>ALIE, Z. v.a. Will €500 Bounty on Wolves reduce Livestock Predation? See the wildest places in Europe [online]. [cit. 2019-11-18]. Dostupné z: https://wilderness-society.org/will-e500-bounty-on-wolves-reduce-livestock-predation/</p> <p>ANTAL, V., MILAN BAROŠ, MARIANA ČERTÍKOVÁ, CIBERA JURJ, DŮCZY JOSEF, FEND O SLOVENSKO, KAŠTĚR PETR, KROPHIL RUDOLF, LUKÁČ JURJ, MOLNÁR LADISLAV, PAULÉ LADISLAV, RIGG ROBERT, RYBANIČ RASTISLAV, ŠRAMKA ŠTEFAN. PROGRAM STAROSTLIVOSTI O VLKA DRAVEHO (Canis lupus) NA SLOVENSKU [online]. In: Banská Bystrica, 2016, s. 115 [cit. 2019-11-18]. Dostupné z: http://www.sopar.sk/files/PS-o-vlka-draveho-na-slovensku.pdf</p> <p>Abschlussbericht zum Projekt „Durchführung von Herdenschutzmaßnahmen in der Weidewirtschaft in Baden-Württemberg“ [online]. [cit. 2020-04-20]. Dostupné z: https://baden-wuerttemberg.nabu.de/import/ndv/content/badenwuerttemberg/themes/praktischernaturschutz/abschlussbericht_herde_mschutz.pdf</p> <p>Mítěco – španělské Ministerstvo pro ekologickou transformaci a demografickou výzvu [online]. [cit. 2020-1-14]. Dostupné z: https://www.miteco.gob.es/es/biodiversidad/temas/conservacion-de-especies/oc_silvestres_resolucion_tubo_ovino_scm30-201439.pdf</p> <p>ROSSI, Aleksandra, BRICE AMAND, BENOÎT GRANDMOUGIN a PIERRE STROSSER. Les moyens de protection des troupeaux domestiques contre le loup dans les nouveaux contextes de prédation [online]. In: 2012, s. 89 [cit. 2019-11-18]. Dostupné z: http://www.auvergne-rhone-alpes.developpement-durable.gouv.fr/IMG/pdf/actcon_loup_contextes_nouveaux_et_mesures_rapport_final_version_2.0.pdf</p> <p>ŠTIKA, Jaroslav. Salabnictví na Moravském Valašsku ve světle literárních pramenů do poloviny 19. století. Etnografica Polaka 5, 1961, s. 87.</p> <p><i>Související zdroje:</i></p> <p>Doporučená optimální opatření pro ochranu hospodářských zvířat před vlky [online]. In: s. 7 [cit. 2019-11-18]. Dostupné z: https://www.sppk.cz/files/documents/storage/2019/08/29/1567063229_Doporuceni_ochrana_opatreni_vlk_OPZP.pdf</p> <p>Blätzel, L., Finfo, S., 2019: Jak pasterveční psi chrání stáda. Metodická příručka pro ochranu stád pomocí pastervečských psů. Metodika AOPK ČR upravené vydání, 43 str. (dostupné zde: https://www.ochranaprirody.cz/publikacni-cinnost/publikace/jak-pastervecci-psi-chranai-stada/)</p> <p>Metodická pomůcka pro vyjádření kompetencí v problematice územních systémů ekologické stability zveřejněná ve Věstníku MŽP č. XXII (2012) (dostupné zde: https://www.mzp.cz/web/odfice.nsf/99EF155AA2F7C4B4C1257A7900286995?file/Vestnik_8_2012.pdf)</p>		

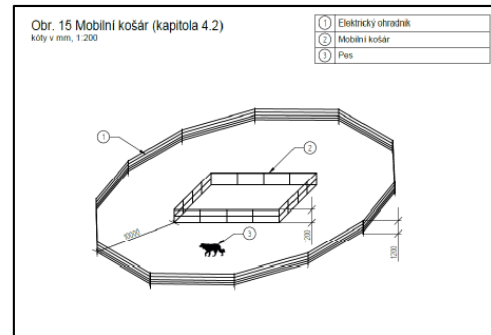

Obr. 15 Mobilní košár (kapitola 4.2)

Obr. 16 Ochrana včelích úlů před útoky medvěda - Elektrický ohradník (kapitola 7.1)

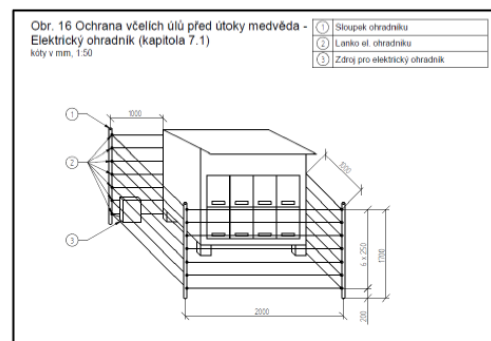

27

14. Figure – Example of preventive measures standards “Livestock Herd Protection against Large Carnivore Attacks” provided by the Nature Conservation Agency of the Czech Republic.

Compensation for restrictions on agricultural management

Compensation for damages caused by selected specially protected animals is provided under Act No. 115/2000 Coll., on Compensation for Damages Caused by Selected Specially Protected Animals. The scheme covers damages caused by species listed in the Act, including the wolf, lynx, and bear.

This instrument is funded from the state budget of the Czech Republic. The Act defines the eligible species and specifies the types of damage that may be compensated, including damage to livestock.

At present, securing livestock in accordance with the official *Standard for the Protection of Livestock against Attacks by Large Carnivores* is not a mandatory condition for receiving compensation. However, a legislative proposal is currently under preparation that would introduce compliance with the Standard as a requirement for eligibility in the future.

Improved perceptions, limited uptake

During the LECA project a survey was carried out in the Beskydy region (2024–2025) to evaluate conflict prevention measures including the implemented financial mitigation tools. Results based on the responses of 62 sheep and goat farmers showed that while awareness of preventive methods is high (92%), most farmers do not utilise available government support: 65% had not applied for funding for preventive equipment, and 74% had not requested support for additional work such as maintaining fences or feeding livestock-guarding dogs. In

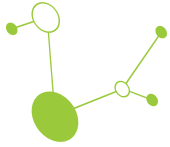

contrast, 78% of farmers who experienced wolf damage applied for compensation, indicating higher willingness to use post-damage financial tools than preventive ones.

Attitudes toward conflict mitigation have shifted over the past decade. Whereas in 2014 only 20% mentioned preventive measures, by 2025 37% now prioritise prevention, and reliance on carnivore regulation has declined (35% compared with 43% in 2014). This suggests that the availability of preventive support has contributed to greater acceptance of non-lethal approaches and potentially increased tolerance of large carnivores. Despite concerns about livestock losses, fewer than 20% now consider wolves pests, while more than 60% recognise their ecological role in regulating ungulates.

Key takeaways

The Czech Republic provides a comprehensive package of subsidies and compensation schemes to support livestock protection and reduce conflict risks, with some tools covering up to 100% of eligible costs. While these instruments form a solid framework for promoting coexistence, farmer uptake of preventive funding remains limited despite high awareness, and most breeders still rely more on post-damage compensation. Nevertheless, attitudes are gradually shifting toward prevention, indicating increasing acceptance of non-lethal approaches as support structures become more accessible.

Case Study 6: Cooperation between practice and education in Slovenia

In Slovenia, several ongoing projects provide preventive measures to farmers who are not eligible for state co-financing—particularly those who have not yet experienced damage caused by large carnivores. These measures include high electric netting for livestock, mobile apiaries, multi-wire electric fences for stationary apiaries, and support for breeding and distributing livestock-guardian dogs from specialised breeders.

As a reference area within the LECA project, Slovenia distributed two complete preventive-measure sets for awareness-raising and educational purposes. One set was provided to a livestock farmer, while the other went to a vocational secondary school specialising in agriculture. The aim was to demonstrate the value of linking practical field experience with formal education. To this end, two field-training sessions were organised for more than 50 students, who observed the application of preventive measures on a working farm. Local hunters involved in wolf capture and telemetry were also invited to explain methods for detecting wolf presence and to introduce the species' biology and behaviour.

Key takeaways

This approach proved highly effective in educating future agricultural practitioners. As a result, the school centre and the participating farm jointly prepared a case study of good practice, which has since been shared with other vocational school centres in Slovenia. The recommendations are intended to support the integration of large-carnivore coexistence topics into regular agricultural curricula under the national LIFE Varna paša project.

Case study 7: Romania's first "Bear-Smart" community - integrated conflict mitigation approach in the Băile Tușnad reference area

The small spa town of Băile Tușnad (~1,700 inhabitants) in Harghita County lies within a major ecological corridor that holds one of Romania's highest brown bear densities (~12.4 bears/100 km²). Once characterised by chronic human-bear conflicts, the town has transformed itself into a model of successful coexistence through the "Bear-Smart Community" approach. Launched in 2022, the initiative is a collaboration between WWF Romania, the Băile Tușnad Town Hall, and the Accent GeoEcological Organisation.

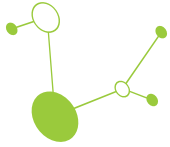

The exceptionally high bear density is partly due to the town’s location along an important movement and dispersal route used by bears and other large mammals across the Eastern Carpathians. The brown bear is also a symbolic species for the community, generating significant tourism revenue through organised bear-watching activities. However, frequent bear intrusions into town had led to habituation to human presence, property damage, heightened fear among residents, and escalating human–bear conflicts.

The initiative therefore aimed to improve coexistence by co-creating and implementing tailored, viable conflict-management solutions through an inclusive and participatory approach. The resulting four-phase “Bear-Smart Community” model is summarised below:

1. **Initiation & Stakeholder Engagement (2022)**
Comprehensive mapping of conflict drivers and participatory planning involving all key actors.
2. **Bear Emergency Team (BET) Operationalisation**
Deployment of GPS/video collars, use of the Cluey app and SensingClues platform for real-time alerts, and implementation of a non-lethal first-response protocol.
3. **Preventive Infrastructure**
Town-wide electric fencing programme (~400 of 600 households and businesses), removal of unprotected fruit trees in high-risk areas, and introduction of prototype bear-proof waste containers.
4. **Communication & Awareness**
Development of the TusnadEcoBearWatch mobile app, the annual TusnadEcoBear Festival and International Conference, and the TusnadEcoBearCave visitor centre (opened 2023, averaging ~5 visitors/hour).

As a result, community surveys show improved attitudes, and bear incursions have become fewer, shorter, and easier to manage. The Bear Emergency Team now functions as a fully collaborative, multi-stakeholder rapid-response unit. The Băile Tuşnad model demonstrates that a prevention-first, participatory, and technology-supported approach can reduce conflicts to near zero—even in high-density bear areas—while strengthening social cohesion and supporting local tourism.

Year	Electric fences installed	Damage incidents	Ro-Alert calls	Bear Festival attendance
2021	limited	41	~230	-
2022	~50-100	5	30	500
2023	~300-400	1	8	1,300
2024	~400	0	14	2,000+
2025	~400	0	5	2,500+

2. Table – Changes in preventive measures and conflict indicators since the start of integrated conflict management

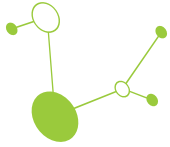

15. Figure – Bear-proof waste containers in Băile Tuşnad (©Cristian-Remus Papp)

Key takeaways

Băile Tuşnad demonstrates that coexistence is achievable even where bear densities are exceptionally high, provided that prevention, participation, and technology are integrated from the outset. By combining improved infrastructure, real-time monitoring, and strong community engagement, the town successfully shifted from chronic conflict to a functional Bear-Smart Community model adaptable to other regions.

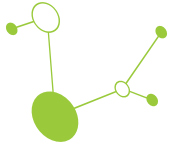

5. Lessons learned: Risks and recommendations

We live in politically dynamic contexts in which the long-term stability of policy approaches and governance frameworks is often uncertain. Changes in government make it difficult to rely on the continuation of established trends or previously adopted policies. Newly elected administrations may introduce measures that dismantle supportive frameworks, such as financial assistance for preventive actions or compensation schemes for damages. They may also weaken systems for monitoring large carnivore occurrences and identifying damage hotspots, thereby reducing protection for livestock breeders, their property, and the carnivores themselves.

Political shifts can additionally lead to institutional restructuring and subsequent personnel changes within key management bodies. If shifts in priorities, insufficient expertise, or a limited understanding of the complexities and causal dynamics of human-wildlife conflict emerge at critical political or institutional levels, even well-established and effective measures may be modified or discontinued.

For example, reduced legal protection of large carnivores and increased authorisation for lethal control can result in the shooting of collared individuals, leading to the loss of valuable long-term data. The disruption of social structures—such as the removal of a breeding pair or the orphaning of cubs—may in turn increase the likelihood that affected individuals seek easily accessible food sources, including livestock or anthropogenic waste near human settlements. Similarly, a relaxation of food-waste management regulations may attract species such as bears into closer proximity to people. Other potentially harmful changes include the dissolution of relevant institutions, budget reductions, redefinition of protected areas, or political narratives that negatively frame large carnivores and associated prevention or compensation measures. Such developments may further influence public attitudes and undermine long-term coexistence strategies.

In order to mitigate potential restrictive changes, it is key to involve local stakeholders and the public in a long-term cooperation. Sustained and meaningful involvement of local stakeholders—particularly livestock breeders, hunters, municipalities, and conservation actors—is essential for building trust and legitimacy in carnivore governance. Transparent communication, participatory decision-making, and continuous feedback mechanisms increase public understanding of management rationales and ecological processes. When communities feel informed and included, policy measures are more resilient to political shifts and less vulnerable to polarisation. Long-term partnerships between governmental agencies, research institutions, NGOs, and local authorities facilitate standardised monitoring, coordinated responses to conflict hotspots, and consistent implementation of preventive measures. Such institutional networks act as buffers against political restructuring and help preserve expertise and operational capacity over time.

Public awareness and active involvement are essential components of sustainable large carnivore management and conflict prevention. Cooperation with schools can foster early understanding of ecological processes, coexistence strategies, and the role of large carnivores in ecosystems, thereby shaping long-term attitudes based on knowledge rather than fear or misinformation. Public events that emphasise engagement and participatory learning—such as workshops, field trips, or community dialogues—can further strengthen trust and create spaces for constructive exchange between authorities, researchers, and local residents. In addition, municipalities should provide clear, transparent, and easily accessible information about large carnivores on their official websites, including guidance on preventive measures, reporting procedures, compensation schemes, and current monitoring results. Readily available information reduces uncertainty, counteracts misinformation, and supports informed decision-making among the public.

Although the previous sections above outlined the most effective and tested tools and practices for mitigating large carnivore conflicts, it is essential to recognise that coexistence is a complex dynamic process. Each conflict is shaped by local socio-economic realities, ecological conditions, and community perceptions; no single measure works everywhere. Every situation requires a degree of tailoring to local contexts.

Unmanaged conflict can undermine wildlife populations and place significant strain on rural communities. Sustainable coexistence therefore demands an integrated, evidence-based approach that combines long-term strategic planning with practical, timely action on the ground, supported by regular evaluation and monitoring.

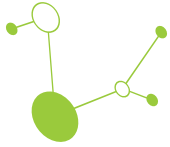

This approach must remain flexible, allowing continuous adaptation to the evolving needs of both stakeholders and wildlife.

Summary of key potential risks and recommendations for their mitigation

Risk/ Obstacle	Category	Description	Impact severity	Mitigation measures	Responsible Actor(s)	Key actors
Missing data on damages caused by large carnivores (LCs)	Operational/ Technical	Insufficient, inconsistent, or non-standardised data collection on livestock damages and carnivore occurrence can lead to underreporting, misidentification of conflict hotspots, and weak evidence for decision-making. Lack of reliable data undermines transparency and public trust.	High --- Compromises adaptive management, weakens compensation systems, and increases stakeholder frustration.	Standardised national protocols for damage reporting and verification Centralised, open-access database for monitoring and damage records Mandatory reporting mechanisms supported by trained field officers Regular publication of summary statistics	National environmental agencies, Wildlife management authorities, Research institutions	Regional authorities, Livestock breeders, Hunters, NGOs, Data analysts
Missing state-funded financial scheme for preventive measures	Political/ Financial	Absence of publicly funded preventive measures (e.g., electric fencing, livestock guarding dogs) places the economic burden entirely on livestock owners. This may reduce uptake of preventive tools and increase hostility toward carnivores.	Very high --- Increases conflict frequency and undermines coexistence strategies.	Establish legally anchored compensation and prevention subsidy schemes Multi-annual funding commitments Co-financing mechanisms (national + EU or regional funds) Simplified administrative procedures to ensure accessibility	National government, Ministry of Environment/Agriculture, Regional administrations	Livestock breeders, EU funding bodies, Municipalities

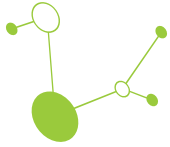

Risk/ Obstacle	Category	Description	Impact severity	Mitigation measures	Responsible Actor(s)	Key actors
Cancellation of existing supportive frameworks	Political/ Institutional	Political turnover may result in the dismantling of established compensation systems, monitoring programs, or conservation measures. Institutional restructuring can disrupt continuity and lead to loss of expertise.	Very high --- Threatens long-term stability of carnivore governance and coexistence efforts	Embed key frameworks in binding legislation Independent scientific advisory boards Multi-level governance alignment (e.g., EU directives) Formalised institutional cooperation agreements	National parliament, Environmental ministries, Independent oversight bodies	Research institutions, NGOs, EU-level authorities, Civil society
Politicisation and negative public narratives	Political	Large carnivores may become politically polarised symbols, leading to simplified narratives that undermine evidence-based management. Negative framing can erode public support for preventive measures and conservation strategies.	High --- Influences policy direction, increases social conflict, reduces trust in institutions	Continuous public engagement and education initiatives Transparent communication of monitoring data and management decisions Stakeholder-inclusive advisory platforms Cooperation with schools and local media	Environmental agencies, Municipalities, Communication units, Educational institutions	Local communities, Media, Schools, NGOs, Researchers

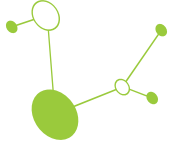

6. References

- Barmoen, M., Bærum, K. M., & Mathiesen, K. E. (2024). Living with wolves: A worldwide systematic review of attitudes. *Ambio*, 53(10), 1414–1432. <https://doi.org/10.1007/s13280-024-02036-1>
- Bautista, C., Revilla, E., Naves, J., Albrecht, J., Fernández, N., Olszańska, A., Adamec, M., Berezowska-Cnota, T., Ciucci, P., Groff, C., Härkönen, S., Huber, D., Jerina, K., Jonozovič, M., Karamanlidis, A. A., Palazón, S., Quenette, P.-Y., Rigg, R., Seijas, J., & Selva, N. (2019). Large carnivore damage in Europe: Analysis of compensation and prevention programs. *Biological Conservation*, 235, 308–316. <https://doi.org/10.1016/j.biocon.2019.04.019>
- Berce, T., & Černe, R. (2016). Reja domačih živali in sobivanje z zvermi - Varovanje drobnice pred velikimi zvermi. Zavod za gozdove Slovenije. Naročnik: Ministrstvo za kmetijstvo, gozdarstvo in prehrano.
- Bereczky, L., Pop, M., & Chiriac, S. (2011). Trouble-Making Brown Bear *Ursus Arctos* Linnaeus, 1758 (Mammalia: Carnivora) - Behavioral Pattern Analysis of the Specialized Individuals. *Travaux Du Muséum National d'Histoire Naturelle "Grigore Antipa"*, 54. <https://doi.org/10.2478/v10191-011-0032-0>
- Bernardi, C. Di, Chapron, G., Kaczensky, P., Álvares, F., Andrén, H., Balys, V., Blanco, J. C., Chiriac, S., Čirović, D., Drouet-Hoguet, N., Huber, D., Iliopoulos, Y., Kojola, I., Krofel, M., Kutal, M., Linnell, J. D. C., Skrbinšek, A. M., Männil, P., Marucco, F., & Boitani, L. (2025). Continuing recovery of wolves in Europe. *PLOS Sustainability and Transformation*, 4(2), e0000158. <https://doi.org/10.1371/journal.pstr.0000158>
- Boitani L., Kaczensky, P., Alvares, F., Andrén, H., Balys, V., Blanco, J.C., Chapron, G., Chiriac, S., Cirovic, D., Drouet-Hoguet, N., Groff, C., Huber, D., Iliopoulos, Z., Ionescu, O., Kojola, I., Krofel, M., Kutal, M., Linnell, J., Majic, A., Mannil, P., Marucco, F., Melovski, D., Mengüllüoğlu, D., Mergeay, J., Nowak, S., Ozolins, J., Perovic, A., Rauer, G., Reinhardt, I., Rigg, R., Salvatori, V., Sanaja, B., Schley, L., Shkvyria, M., Sunde, P., Tirronen, K., Trajce, A., Trbojevic, I., Trouwborst, A., von Arx, M., Wolf, M., Zlatanova, D. & Patkó, L. (2022). Assessment of the conservation status of the Wolf (*Canis lupus*) in Europe. *Council of Europe & Bern Convention*.
- Bright, A. D., & Manfredi, M. J. (1996). A conceptual model of attitudes toward natural resource issues: A case study of wolf reintroduction. *Human Dimensions of Wildlife*, 1(1), 1–21. <https://doi.org/10.1080/10871209609359048>
- Bruskotter, J. T., Schmidt, R. H., & Teel, T. L. (2007). Are attitudes toward wolves changing? A case study in Utah. *Biological Conservation*, 139(1–2), 211–218. <https://doi.org/10.1016/j.biocon.2007.06.016>
- Bulte, E. H., & Rondeau, D. (2005). Why Compensating Wildlife Damages May Be Bad for Conservation. *The Journal of Wildlife Management*, 69(1), 14–19. <http://www.jstor.org/stable/3803581>
- Chapron, G., Kaczensky, P., Linnell, J. D. C., von Arx, M., Huber, D., Andrén, H., López-Bao, J. V., Adamec, M., Álvares, F., Anders, O., Balčiauskas, L., Balys, V., Bedó, P., Bego, F., Blanco, J. C., Breitenmoser, U., Brøseth, H., Bufka, L., Bunikyte, R., ... Boitani, L. (2014). Recovery of large carnivores in Europe's modern human-dominated landscapes. *Science*, 346(6216), 1517–1519. <https://doi.org/10.1126/science.1257553>
- Creachbaum, M. S., Johnson, C., & Schmidt, R. H. (1998). Living on the edge: a process for redesigning campgrounds in grizzly bear habitat. *Landscape and Urban Planning*, 42(2–4), 269–286. [https://doi.org/10.1016/S0169-2046\(98\)00092-9](https://doi.org/10.1016/S0169-2046(98)00092-9)
- Dickman, A., Marchini, S., & Manfredi, M. (2013). The human dimension in addressing conflict with large carnivores. *Key Topics in Conservation Biology*, 2, 110–126. <https://doi.org/10.1002/9781118520178.ch7>
- Dressel, S., Sandström, C., & Ericsson, G. (2015). A meta-analysis of studies on attitudes toward bears and wolves across Europe 1976–2012. *Conservation Biology*, 29(2), 565–574. <https://doi.org/10.1111/COBI.12420>
- Elfström, M., Davey, M. L., Zedrosser, A., Müller, M., De Barba, M., Støen, O. G., Miquel, C., Taberlet, P., Hackländer, K., & Swenson, J. E. (2014). Do Scandinavian brown bears approach settlements to obtain high-quality food? *Biological Conservation*, 178(4), 128–135. <https://doi.org/10.1016/j.biocon.2014.08.003>

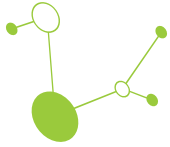

- Elfström, M., Zedrosser, A., Jerina, K., Støen, O. G., Kindberg, J., Budic, L., Jonozovič, M., & Swenson, J. E. (2014). Does despotic behavior or food search explain the occurrence of problem brown bears in Europe? *Journal of Wildlife Management*, 78(5), 881–893. <https://doi.org/10.1002/jwmg.727>
- Ericsson, G., & Heberlein, T. A. (2003). Attitudes of hunters, locals, and the general public in Sweden now that the wolves are back. *Biological Conservation*, 111(2), 149–159. [https://doi.org/10.1016/S0006-3207\(02\)00258-6](https://doi.org/10.1016/S0006-3207(02)00258-6)
- Eriksson, M., Sandström, C., & Ericsson, G. (2015). Direct experience and attitude change towards bears and wolves. *Wildlife Biology*, 21(3), 131–137. <https://doi.org/10.2981/wlb.00062>
- Frank, J., & Eklund, A. (2017). Poor construction, not time, takes its toll on subsidised fences designed to deter large carnivores. *PLOS ONE*, 12(4), e0175211. <https://doi.org/10.1371/journal.pone.0175211>
- Herrero, S., Smith, T., DeBruyn, T. D., Gunther, K., & Matt, C. A. (2005). Brown Bear Habituation to People: Safety, Risks, and Benefits. *Wildlife Society Bulletin (1973-2006)*, 33(1), 362–373. <http://www.jstor.org/stable/3784879>
- Jope, K. L. (1985). Implications of Grizzly Bear Habituation to Hikers. *Wildlife Society Bulletin (1973-2006)*, 13(1), 32–37. <http://www.jstor.org/stable/3781944>
- Kikvidze, Z., & Tevzadze, G. (2014). Loss of traditional knowledge aggravates wolf–human conflict in Georgia (Caucasus) in the wake of socio-economic change. *Ambio*, 44(5), 452–457. <https://doi.org/10.1007/s13280-014-0580-1>
- Lackey, C., Telesco, D., Annis, K., Battle, D., Cooley, H., Frame, P., Mangipane, L., Olfenbuttel, C., Vieira, M., & Waldrop, T. (2025). Changing the narrative on human–bear conflicts by standardizing bear management terms. <https://doi.org/10.2192/URSUS-D-24-00008R1>, 2025(36e4), 1–10. <https://doi.org/10.2192/URSUS-D-24-00008R1>
- Lescureux, N., & Linnell, J. D. C. (2014). Warring brothers: The complex interactions between wolves (*Canis lupus*) and dogs (*Canis familiaris*) in a conservation context. *Biological Conservation*, 171, 232–245. <https://doi.org/10.1016/j.biocon.2014.01.032>
- Linnell, J. D. C. (2013). From conflict to coexistence? Insights from multi-disciplinary research into the relationships between people, large carnivores and institutions. https://ec.europa.eu/environment/nature/conservation/species/carnivores/pdf/task_4_conflict_coexistence.pdf
- Linnell, J. D. C., & Cretois, B. (2018). Research for AGRI Committee - The revival of wolves and other large predators and its impact on farmers and their livelihood in rural regions of Europe.
- Linnell, J. D. C., Odden, J., & Mertens, A. (2012). Mitigation methods for conflicts associated with carnivore depredation on livestock. *Carnivore Ecology and Conservation*, 314–332. <https://doi.org/10.1093/ACPROF:OSO/9780199558520.003.0014>
- Linnell, J., & Lescureux, N. (2015). Livestock guarding dogs – cultural heritage icons with a new relevance for mitigating conservation conflicts. *Norwegian Institute for Nature Research*.
- Lorand, C., Robert, A., Gastineau, A., Mihoub, J. B., & Bessa-Gomes, C. (2022). Effectiveness of interventions for managing human-large carnivore conflicts worldwide: Scare them off, don't remove them. *Science of The Total Environment*, 838, 156195. <https://doi.org/10.1016/j.scitotenv.2022.156195>
- MacLennan, S. D., Groom, R. J., Macdonald, D. W., & Frank, L. G. (2009). Evaluation of a compensation scheme to bring about pastoralist tolerance of lions. *Biological Conservation*, 142(11), 2419–2427. <https://doi.org/10.1016/j.biocon.2008.12.003>
- Madden, F. M. (2008). The Growing Conflict Between Humans and Wildlife: Law and Policy as Contributing and Mitigating Factors. *Journal of International Wildlife Law & Policy*, 11(2–3), 189–206. <https://doi.org/10.1080/13880290802470281>

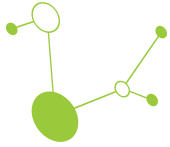

- Musiani, M., & Visalberghi, E. (2001). Effectiveness of Fladry on Wolves in Captivity. *Wildlife Society Bulletin (1973-2006)*, 29(1), 91–98. <http://www.jstor.org/stable/3783985>
- Nyhus, P. J., Osofsky, S. A., Ferraro, P., Madden, F., & Fischer, H. (2005). Bearing the costs of human–wildlife conflict: the challenges of compensation schemes. In R. Woodroffe, S. Thirgood, & A. Rabinowitz (Eds.), *People and Wildlife, Conflict or Co-existence?* (pp. 107–121). *Cambridge University Press*. <https://doi.org/DOI:10.1017/CBO9780511614774.008>
- Oliveira, T., Treves, A., López-Bao, J. V., & Krofel, M. (2021). The contribution of the LIFE program to mitigating damages caused by large carnivores in Europe. *Global Ecology and Conservation*, 31, e01815. <https://doi.org/10.1016/j.gecco.2021.e01815>
- Redpath, S. M., Young, J., Evely, A., Adams, W. M., Sutherland, W. J., Whitehouse, A., Amar, A., Lambert, R. A., Linnell, J. D. C., Watt, A., & Gutiérrez, R. J. (2013). Understanding and managing conservation conflicts. *Trends in Ecology & Evolution*, 28(2), 100–109. <https://doi.org/10.1016/j.tree.2012.08.021>
- Salvatori, V., Balian, E., Blanco, J. C., Ciucci, P., Demeter, L., Hartel, T., Marsden, K., Redpath, S. M., von Korff, Y., & Young, J. C. (2020). Applying Participatory Processes to Address Conflicts Over the Conservation of Large Carnivores: Understanding Conditions for Successful Management. *Frontiers in Ecology and Evolution*, 8, 494770. <https://doi.org/10.3389/fevo.2020.00182>
- Sato, Y., Mano, T., & Takatsuki, S. (2005). Stomach contents of brown bears *Ursus arctos* in Hokkaido, Japan. [https://doi.org/10.2981/0909-6396\(2005\)11\[133:SCOBBU\]2.0.CO;2](https://doi.org/10.2981/0909-6396(2005)11[133:SCOBBU]2.0.CO;2), 11(2), 133–144. <https://doi.org/10.2981/0909>
- Swenson, J. E. (2000). Action Plan for the conservation of the Brown Bear (*Ursus arctos*) in Europe.
- TEEL, T. L., & MANFREDO, M. J. (2010). Understanding the Diversity of Public Interests in Wildlife Conservation. *Conservation Biology*, 24(1), 128–139. <https://doi.org/10.1111/j.1523-1739.2009.01374.x>
- Trajçe, A., Ivanov, G., Keçi, E., Majić, A., Melovski, D., Mersini, K., Mustafa, S., Skrbinšek, T., Stojanov, A., Todorovska, A., von Arx, M., & Linnell, J. D. C. (2019). All carnivores are not equal in the rural people's view. Should we develop conservation plans for functional guilds or individual species in the face of conflicts? *Global Ecology and Conservation*, 19(3), e00677. <https://doi.org/10.1016/j.gecco.2019.e00677>
- Treves, A., Naughton-Treves, L., Harper, E. K., Mladenoff, D. J., Rose, R. A., Sickley, T. A., & Wydeven, A. P. (2004). Predicting Human-Carnivore Conflict: A Spatial Model Derived from 25 Years of Data on Wolf Predation on Livestock. *Conservation Biology*, 18(1), 114–125. <https://doi.org/10.1111/j.1523-1739.2004.00189.x>
- Venter, O., Sanderson, E. W., Magrath, A., Allan, J. R., Beher, J., Jones, K. R., Possingham, H. P., Laurance, W. F., Wood, P., Fekete, B. M., Levy, M. A., & Watson, J. E. M. (2016). Sixteen years of change in the global terrestrial human footprint and implications for biodiversity conservation. *Nature Communications*, 7(1), 12558-. <https://doi.org/10.1038/ncomms12558>
- Wilson, S. M., Madel, M. J., Mattson, D. J., Graham, J. M., & Merrill, T. (2006). Landscape conditions predisposing grizzly bears to conflicts on private agricultural lands in the western USA. *Biological Conservation*, 130(1), 47–59. <https://doi.org/10.1016/j.biocon.2005.12.001>